

PAPER-EDI



EDI functionality via 2D Code for supply chain application in industry and healthcare

„EDI Code & SET Code“

Version of the P'EDI structure: 2
Document version: 2024-02-26-EN

Preface

Manufacturers, retailers and users are communicating ever more closely with one another in order to optimize logistics in the supply chains. This applies to electronic communication from computer to computer too, but the products and package were also taught how they can communicate electronically, namely by help of barcodes. Barcode is considered a secure medium for simplifying, accelerating and securing all recording processes. Legislators have also recognized the advantages of the barcode as a medium for automatic identification using a unique barcode. For Medical Devices and In-vitro-Diagnostica, the prescribed medium is the **UDI code**.

Once the deadline for **UDI** has been reached, all products in this category can be recorded electronically, individually. On shipment level PaperEDI is filling the information gap in all cases, where „Electronic Data Interchange (EDI) would not be available for transmitting the shipment contents.

This means that with PaperEDI the electronic message is practically "on the man" and offers automatic recording by scanning at any location at any time, regardless of whether there is a network or not.

UDI brings further optimization potential with it, namely a harmonized data format that is used for the product references as UDI-DI's for the public UDI databases (GUDID, EUDAMED, etc.), also at the manufacturers and users sites. The working group AIDC has taken up this and included the harmonized format for UDI-DI's in the PaperEDI standard. Chapter "3.2.5.1 UDI-DI as product/article reference" describes the optimization through harmonized product references in detail.

The first edition of "PaperEDI" was released on May 23, 2006 by the "Joined Working Group AIDC" (BVD, EDCi, EHIBCC, FIDE, SPECTARIS, VDDI); With today's update, especially with the inclusion of UDI, the document has received the status of a top actuality.

With the change of the HIBC support to Phoenix / Arizona USA at the end of 2019, the coordination for the maintenance of the PaperEDI standard was taken over by the E-D-C. The document is now synchronized with associations in other industries, such as the electronics and automotive industries, and with updates to the ISO standards. Although the focus of the working group is on medical devices and UDI, the solution PaperEDI is serving for all other areas as in healthcare as in industries.

The current edition is available on the Internet at www.e-d-c.info.

John-Marco Fader
(Chairman)

Updates

This document is maintained by the Technical Committee. The following updates have been made since the first edition, see change table:

Change table

Date	Action	Theme
2008-09-05	complement	Integration Data Identifier (26Q) HIBC Unit of Measure
2009-09-25	complement	Adding the sample delivery note supplied by VITA
2012-03-13	update	Replacing DI "13Q" with DI "4F" for the page references, inserting "terms", update of texts and samples
2012-05-07	update	Corrective editing and examples
2013-04-08	complement	Internet link, attachments for invoices, set labels, P'EDI emblem
2013-11-26	complement	New DI for GMDN (29P), new attachments for quotation, and invoice
2013-11-29	complement	Working group meeting: New attachments: order confirmation, Consi call-off, Consi consumption, credit note, returns
2014-04-07	update	Inappropriate DI 8V (customer code by customer) replaced by "V" supplier code by customer. Both sample codes renewed.
2014-04-24	update	Paper EDI invoice: Requested DIs inserted in Table 11
2014-11-10	update	Chapter "4.1 Selection of data elements" and Table 1 "EDI field for data identifiers" removed, as these are more confusing than helpful. 12P values in Table 2 "Document types" corrected. Chapter 4.6: "12PDESADV" incorporated into the example
2016-07-21	update	Table 1 mentioned that there might be other expiration date formats. These are not recommended anymore, comment removed.
2020-04-15	address	Change of the support address to www.e-d-c.info
2020-10-20	update	UDI with ASC DI "54P" included.
2021-01-07	update	Chapter 4 and Annexes B, E, K revised: <ul style="list-style-type: none"> Replacing „no. of pages“ with „no. of symbols“ Barcode references with 54P, 25P, 8P, 9N removed Pattern with tremas ("umlaut") in the batch. Annex A reformulated with notes for migration.
2021-05-10	update	Note in chapter 4.6 that header data do not have to be repeated from the second page. In chapter 4.1 the data elements for patient reference and medical parameters were added. Document "Appendix P: Patient-related data elements" added to main document.
2021-07-01	update	Precise Date formats added for Delivery Note, Order, Invoice.

Continuation of change table see next page

Continuation of the change table

Date	Action	Content
2022-11-29	Supplement	<ul style="list-style-type: none"> • Inclusion of data element for medical parameters with ASC DI "32Q-Clinical term code (LOINC code)", replacing interim solution with "11Y". • Note in chapter 4.7 that from the second page only the shipper code is repeated. • The consignment process was changed as follows (Appendix): <ul style="list-style-type: none"> ◦ The document type for "Consignment stock replenishment) is changed from "ORDERS" to "CONORDERS". ◦ New document type "CONDESADV" for delivery to the consignment warehouse, new appendix "H". ◦ New document type for requesting a return delivery from the consignment warehouse, new appendix "I". • Modification of non-unique document types (Appendix): <ul style="list-style-type: none"> ◦ Order confirmation: from "QUOTES" to "ORDRSP". ◦ Return delivery: from "DESADV" to "BACDESADV".
2022-11-30	Supplement	Insertion of keyboard & WEB compatible syntax DIN 16598 in chapter 4 and example coding of national characters (tremla) in chapter 4.16
2022-12-15	Editorials	Synchronisation with version "DE"
2024-02-26	Correction	Figure 16: Data Matrix human readable interpretation synchronised with the code content.

CONTENT

1	Terms.....	7
2	EDI and Barcode for supply chain management.....	8
2.1	Electronic Data Interchange per UN/EDIFACT.....	8
3	PaperEDI.....	9
3.1	Technologies/symbologies to carry „Paper-EDI“.....	9
3.2	Four advantages of „Paper-EDI“.....	10
3.3	Who can benefit from the advantages of "PaperEDI".....	10
3.4	Requirements for an end-to-end "PaperEDI" system.....	10
3.5	Numbering structures of products carried by „PaperEDI“.....	10
3.5.1	Supplier part number.....	10
3.5.2	Product/Article reference.....	11
3.5.2.1	UDI-DI as product article reference.....	11
3.5.3	Patient references and medical parameters for customer-specific work.....	12
3.6	A typical process in a "PaperEDI system.....	13
3.6.1	The components of a Paper EDI system.....	13
3.7	Technical realization.....	14
3.7.1	Picking.....	14
3.7.2	Handling different codes when picking.....	14
3.7.3	Interface from the system to generate PaperEDI.....	14
3.7.4	Steps for the production of a PaperEDI mark.....	15
4	Syntax for PaperEDI.....	16
4.1	Syntax for High Capacity Media ISO/IEC 15434.....	16
4.2	Keyboard and WEB compatible syntax DIN 16598 for „Paper-EDI“.....	17
4.3	Data elements for the EDI mark and their data identifiers.....	18
4.4	Document type.....	19
4.5	PIC of the sender.....	19
4.6	Supplier product code.....	20
4.7	UDI Bar coded product reference on the product and within PaperEDI.....	20
4.8	Patient reference and medical parameter.....	20
4.9	Distribution of data information to multiple code symbols.....	21
4.10	Hierarchy of data in a PaperEDI message.....	23
4.10.1	Data Identifier „F“ for hierarchical structuring and optimization of the messages.....	23
4.10.1.1	The logic of the hierarchy.....	24
4.10.1.2	Graphical representation of the logic.....	25
4.10.2	Structure of a delivery message before grouping.....	25
4.10.3	Compaction.....	26
4.10.3.1	Grouping the data into the hierarchy.....	27
4.10.4	Optimization rules for "F-sequences.....	28
4.11	Concatenation of data segments before embedding in the syntax ISO/IEC 15434.....	29
4.12	Embedding of the message in ISO/IEC 15434 and representation as Data Matrix.....	30
4.13	Concatenation of data segments and embedding in syntax DIN 16598.....	30
4.14	Inserting the PaperEDI symbol into the delivery note.....	31
4.15	Reading the example PaperEDI.....	32
4.16	National special characters (tremas).....	34

Appendix A: Compatibility with previous versions.....	36
A.1: Use of DI "13Q" for page/symbol references.....	36
A.2: Use/replacement of the "Issuing Agency Code (IAC)" of EHIBCC "LH".....	36
A.3: From product code/dealer number to sender item number and UDI barcode reference	36
A.3.1 Barcode type.....	37
A.3.2 Manufacturer product or the trader's reference.....	37
A.3.3 PaperEDI Version 1.....	37
A.3.4 PaperEDI Version 2.....	38
Appendix B: EDI-Mark for invoices.....	39
Appendix C: Combined delivery note with invoice.....	40
Appendix D: P'EDI QUOTATION.....	40
Appendix E: P'EDI ORDER.....	41
Appendix F: Order confirmation.....	41
Appendix G: Consignment stock filling request.....	41
Appendix H: Consignment replenishment.....	41
5 Appendix I: Consignment warehouse return delivery request.....	41
Appendix J: Consignment stock consumption.....	41
Appendix K: Credit note.....	42
Appendix L: Return delivery.....	42
Appendix M: SET Code.....	43
M1: Data elements of a SET Code.....	43
M2: Structure and syntax of a SET code.....	43
Appendix N: Emblem P'EDI and SET.....	44
N1: Emblem P'EDI.....	44
N2: Emblem „SET“.....	44
Appendix O: Internet link to general, process and object related information.....	44
Appendix P: P'EDI via data line.....	45
Appendix Q: Standards, references and sources.....	45

1 Terms

ASC DI	Data Identifier according to ISO/IEC 15418, part ANSI MH 10.8.2 „ASC Data Identifiers“, see also „DI“
DI	Data Identifier according to ISO/IEC 15418, part ANS MH 10.8.2 „ASC Data Identifiers“, see also „ASC DI“
EDI	Electronic Data Interchange between partners to business processes, here deliveries
EDI Mark	2D Symbol with structured data for electronic data information
Group ID	Common reference number of a related group of symbols.
LOINC Code	Clinical Term Code, according to the Clinical Nomenclature: "The international standard for identifying health measurements, observations, and documents - LOINC" (https://loinc.org). A LOINC code is indicated as a data element in P'EDI by the ASC DI "32Q".
P'EDI	Short term and emblem for a PaperEDI code.
PaperEDI	Method for electronic data information via delivery paper or label
P'EDI	Short term and emblem for PaperEDI
PIC	Party Identification Code according to ISO/IEC 15459, Consists of an Issuing Agency Code (IAC) followed by the registered Company Identification Number (CIN).
PPN	Pharma Produkt Number according to the IFA Coding System
PZN	8-digit Pharmaceutical Central Number. Barcode for medicinal products with the prefix "-" in Code 39 or as PPN in Data Matrix. Despite of the word "Pharma", 80% of the products are medical devices.
SET-Code	2D code with structured data elements of a set of related products included in packaging, containers or devices.
Symbol	A linear or 2D Barcode
Symbology	Code type of barcode or 2D symbols. The symbologies used here are "Data Matrix" or "QR Code".
UDI	„Unique Device Identification“, term for unique labeling for the traceability of medical devices and In-vitro-Diagnostica according to MDR and IvDR regulations for Europe and according to the IMDRF guidelines worldwide.
UDI-DI	Unique Identification - Device Identifier: Article reference within the UDI system. This is a string that is encoded in a barcode and registered in the UDI databases as a reference to MP or IvD. The format is specified by the issuing entities GS1, HIBC, ICCBBA, IFA. The harmonized format for the different formats of a UDI-DI is formed by help of the ASC DI "54P" and compatible with the key data element UDI-DI in a UDI database.
UDI-PI	Unique Identification – Production Identifier: The variable product data in an UDI barcode, which includes data elements like expiry date, manufacturing data, lot number or serial number or all together.

2 EDI and Barcode for supply chain management

There is always a direct relation between Barcode data and data transmitted via EDI if the EDI message contains shipment information. A function of Barcode is to confirm a shipment and its arrival being attached to the physical shipment. Therefore it fills a gap as one module of EDI based communication systems. But Barcode cannot only keep unique transport numbers. The capacity of 2-dimensional Barcode options allows to carry the content of shipment content details as well. Carrying EDI messages on the shipment label Barcode can be read off-line where ever the content of the transport unit should be communicated to local a computer. The feature would support EDI projects and extend the functionality at locations where no access to EDI systems is given or no EDI system is installed. The specification PaperEDI shall give guidance how to generate, to print and to read such 2-D codes carrying shipment information for data capture at any time and at any place.

2.1 Electronic Data Interchange per UN/EDIFACT

EDI stands for Electronic Data Interchange a method for data communication between trading partners. EDI has been in use since along time supporting structured business processes. It consists of standardized messages as for ordering, shipments, invoicing and many more. This specification is focusing on support of shipment related messages only based on the standardized structure UN EDIFACT (Electronic Data Interchange for Administration Commerce and Transport). The principle can be used in conjunction with any other message structure or syntax like XML. A 2D-Barcode can carry the Dispatch Advise message to the destination as well enabling automatic data capture very quickly by a scanner avoiding any manual key entry and avoiding errors.

PaperEDI is enabling data capture in real time making the data available for processing without any delay. Shipments need not to even be unpacked and can be passed straight to the stock destination where the ERP system would get the full content from scanning the EDI-Mark. Keeping the data to the object handling will be optimized, errors avoided and transmission times reduced. In case of full EDI supported operations PaperEDI will supply a functional back up.

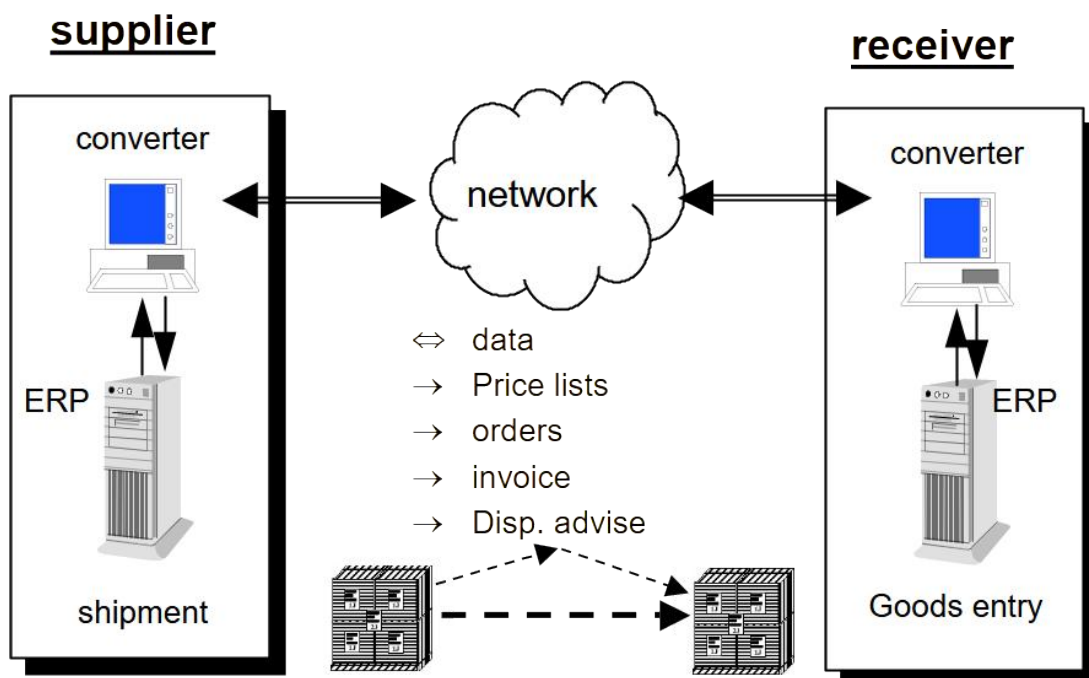

Figure 1: Components of an EDI communication path

Where EDI transmits the data via a network Barcode carries true data right with the object. A typical supply scenario shall be described as follows.

An order received via EDI would initiate order acknowledge and processing and. Orders can be passed fully automatically, manual interference might be necessary only if deviations occur. If the shipment is ready for delivery the electronic Dispatch Advise will inform the customer about the potential arrival.

The Barcode on the shipment as unique “License Plate” (see chapter 15 Multi Industry Transport Label) will be printed on the label, on the shipment paper and send via EDI as well. If the shipment arrived an the License Pate has been scanned the ERP system can link the arrival data to the EDI message already received.

Electronically transmitted invoicing completes such a fully automated process. The EDI message and the acknowledgment by Barcode can be archived simultaneously without any manual operation.

The combination of EDI and Barcode enables coupling the data information to the physical processes.

Where the License Plate is the unique transport number to verify the shipments the products in it are commonly labeled with unique product codes such as Healthcare Barcode (HIBC). Both are referenced with the relevant EDI messages. Scan information and EDI information will be send by different technologies to a different time but matched within the ERP system at both end of the supply chain.

3 PaperEDI

Electronic data communication supports tracking and tracing and related documentation nicely. Potential errors will be avoided by minimizing manual entries. EDI is ideal but requires B2B agreements to preferably any business partner. If EDI messages cannot or not yet be processed by a partner, then Automatic Identification and Data Capture (AIDC) can bridge the gap by means of an “EDI Mark”. An EDI Mark is a high capacity two-dimensional Barcode carrying data information compatible to an EDI message. Where PDF 417, QR Code and DATAMATRIX are the most used data carriers for that purpose, high capacity RFID Tags could be used as well as an option. Other developments such as „E-Paper“ (electronically write/readable paper) might be available in the future as an option as well. The specification „**PaperEDI**“ will focus on the use of DataMatrix today. “PaperEDI” consist of the shipment reference and shipment content data in a structured manner and the carrier DataMatrix. This combination is called „**EDI-Mark**“. The supplier completing a shipment might send the related data information to an “EDI Box” (EDI converter) and to the print shop for delivery paper and/or shipment label simultaneously. Belonging data elements are the License Plate as shipment reference and shipped products including product relevant data such as expiry, LOT and/or serial numbers. Receivers of the shipment than will have access to the data information via EDI and/or EDI Mark.

3.1 Technologies/symbologies to carry „Paper-EDI“

The preferred symbology for PaperEDI is DataMatrix because of the feature of automatic error correction setting. Nevertheless other standardized symbology might be used alternatively such as QR-Code. For QR-Code Error Correction level is not set automatically but needs to be determined by the application).

The ISO/IEC specifications for these symbology are:

DATA MATRIX ISO/IEC 16022,
includes automatic error correction,



QR code ISO/IEC 18004 can also be used
but only with appropriate
setting of the error correction level.



RFID, see below



The choice RFID is initially only recommended in connection with automated processes harmonized between the supply partners. "ISO/IEC TR 29162 Guidelines for using data structures in AIDC media" is recommended as a guideline for the use of RFID.

3.2 Four advantages of „Paper-EDI“

▪ Rationalization

With the minimum effort of an additional 2D code to the text, rational handling can be achieved wherever the delivery contents are to be recorded. Without unpacking, one scan is sufficient to capture the information about the content of a delivery carried by the P'EDI Code (RFID transponders could achieve the same thing, but at increased efforts).

▪ Handling speed

Experience has shown that goods entry processes can be accelerated by a factor of 6, i.e. instead of 1.5 days, only 1.5 hours are required to take in and to register the goods.

▪ Safety and accuracy

Through PaperEDI, safety by data accuracy is achieved by avoiding errors: no typing, no duplication or missing entries, as it would happen with single scanning of each item.

▪ Automatic compliance with regulations requiring documentation

For example, the regulations for medical devices MDR and for In-vitro-Diagnostica IvDR require that specific products held in-house are documented with their UDI-DI and UDI-PI (date, LOT, SN). With PaperEDI this can be fulfilled automatically at goods receipt.

3.3 Who can benefit from the advantages of "PaperEDI"

All parties involved in a national or international supply chain, e.g.:

- The manufacturer for verification of package contents at external storage locations
- The distributor for capturing incoming goods (without unpacking), for outgoing goods and service to the customer.
- The goods recipient, e.g. in healthcare the hospital and the doctor's practices.

3.4 Requirements for an end-to-end "PaperEDI" system

The basis for a good system is standardized product marking by barcode prior to P'EDI. In this case accurate recording of the „picked“ products will enable that delivery notes applied with PaperEDI get accurate data, so that the actual product data with batch/serial number/expiry date can be carried in a 1:1 relation. At the recipient's end, this includes an incoming goods system that can manage the shipment data with product variables, i.e. expiration dates, batches, serial numbers. To generate P'EDI Data Matrix and also to decode it there are tools available for both ends of the supply chain for cases where the ERP systems do not process data structures of barcode like ISO/IEC 15434 Syntax for high capacity media.

3.5 Numbering structures of products carried by „PaperEDI“

PaperEDI is capable to process alphanumeric product numbers of variable length. The product/article numbers coming from codes other than ASC DI structures will be converted to become compatible. PaperEDI can carry the part number of the supplier and/or of the ordering party.

3.5.1 Supplier part number

In contrast to the manufacturer's product reference, the supplier article number is primarily decisive for business processes such as ordering, delivery bill and invoice.

The supplier article number is valid in the supplier's business processes and may not be globally unique on its own, unless it is a UDI-DI or similar.

The supplier can be both a manufacturer and a distributor.

3.5.2 Product/Article reference

The item reference on the product is either represented directly by the barcode reference, or has a corresponding secondary reference in barcode. In PaperEDI both can be represented.

3.5.2.1 UDI-DI as product article reference

a) UDI on the product

On the physical product and packaging level, UDI codes are provided in one of the code systems accredited for UDI, which are currently GS1, HIBC, ISBT and in Europe the IFA Coding System.

b) Unique Device Identifier (UDI-DI) in the databases

In the UDI databases (GUDID, EUDAMED, ...) the UDI-DI's are registered without any system or data identifiers and are publicly accessible together with the registered master data via this key.

c) UDI in PaperEDI

On the product, UDI-DI as product reference, as well as the UDI-PI (Unique Device Production Identifier) data, which may include expiry date, manufacturing date, LOT, SN and med. parameters, are encoded e.g. in DataMatrix.

In PaperEDI, these data elements are represented as individual but related data fields.

UDI DI's are carried in a PaperEDI mark in the format of the UDI databases (b) and carried on the product flagged with the ASC DI "54P". The associated value corresponds to the UDI DI, but without the "GS1 AI" or "ASC DI" used on the product itself.

This harmonizing ASC DI „54P“ allows to encode the UDI-DI's in the PaperEDI syntax, where the UDI-DI remains in the structure of the chosen barcode format (GS1, HIBC, IFA, ...). This solution allows direct access to the UDI databases for downloading the UDI master data at the point of data capture.

Figure 2) shows the application of ASC DI "54P" and synchronization of UDI-DI's in the formats for product, databases and paper EDI.

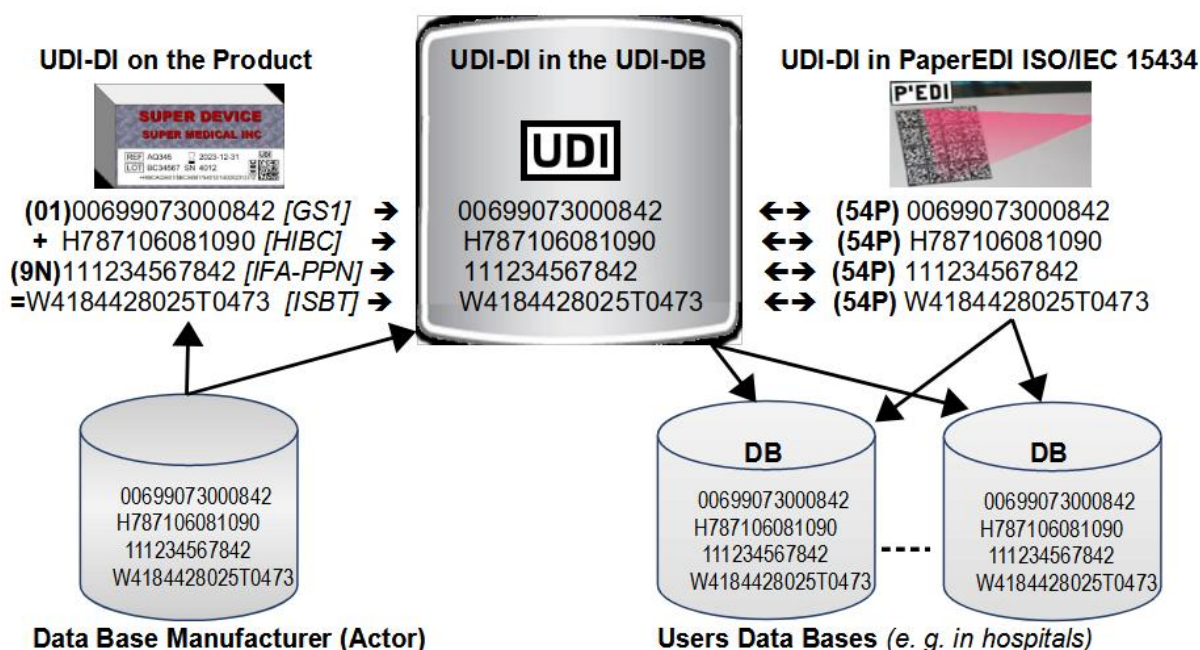

Figure 2: UDI-DI formatted for product identification, in the UDI databases and carried in PaperEDI (Source: H.Oehlmann)

c) UDI in PaperEDI continued

UDI-PI data is inserted into the P'EDI tree structure as individual data fields and quoted with the corresponding ASC DI's:

- "14D" Expiration date
- "16D" date of manufacture
- "1T" LOT
- "S" SN

Note: If applicable, "32Q" LOINC code for medical parameters may be added (see 3.5.3).

3.5.3 Patient references and medical parameters for customer-specific work

In addition to the customer's order number (K), specific patient references and medical parameters can be added to the order and delivery bill in PaperEDI, for example:

- Patient reference, value + parameter
DI „H“, patient reference/name plus parameter, e.g. „LK“: <H><Name><+><LK>
Beispiel Referenz „10203040“: **H10203040+LK**
- Medical parameter according to LOINC nomenclature (*see chapter 1. Terms*)
DI „32Q“: <32Q><LOINC Code><+><value>
Example of medical parameter for tooth position, e.g. "32".: LOINC-Code „32884-9“:
32Q 32884-9+32

See: <https://loinc.org/32884-9/> Common Name: Identification {Tooth}

Description: Identifies the 20 primary teeth, 32 permanent teeth, supernumerary teeth, as well as implants, abutments and pontics.

3.6 A typical process in a "PaperEDI system

The purpose of electronic data transmission is to transmit data information without errors and avoiding manual data entries at the receiving point. This includes ensuring that the products are also recorded without errors during picking and packing at the suppliers side. Typically this will be realized by help of mobile data capture devices. Once the data entry process is complete, the data will be transferred to the ERP system and the delivery note can be printed and applied with an "EDI mark". At „goods exit“ the delivery bill with "EDI mark" will be attached to the transport unit, or a transport label will be printed with „EDI Mark“ (see section 19. Multi-Industry Transport Label - MITL). At goods entry at any further destination or location, the delivery note or transport label can be scanned for error free and quick data entry at any time. The data are accurately available where ever the transport unit will turn up.

Goods exit: The shipment now leaves the premises by carrier directly to the customer or to intermediate warehouses. It enables that at each location, it will be possible to scan the delivery note/label for access to the shipment content.

Goods entry: When goods are received at the destination, the delivery note/label can be scanned and the delivery data will be transferred to the local system immediately, without any further unpacking. The product data and variables can be processed for starting further processes like intermediate storage, filling the stock, production and administration. From the moment of scanning the data are available traceability as well.

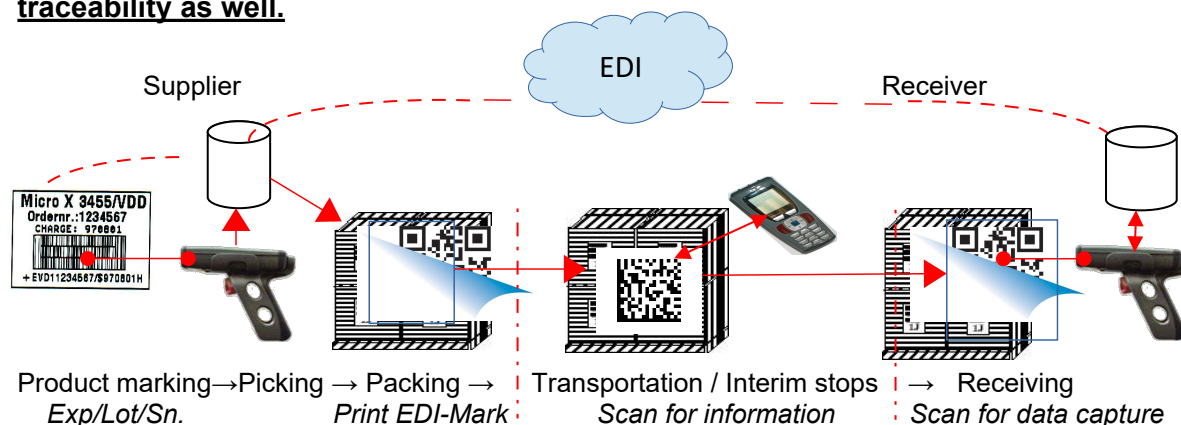

Figure 3: Flow of goods and data flow

3.6.1 The components of a Paper EDI system

The components of a PaperEDI system are the data carrier (e.g. Data Matrix), the ISO/IEC 15434 Syntax for High Capacity Media and the ASC data identifiers according to ISO/IEC 15418, part ASC MH 10.8.2. These components carry the information securely to its destination. The components have been widely recognized since the 1990s in industrial sectors such as electronics, automotive, and the automotive supply industry, and are now also established in the healthcare sector.

Equipment on supplier's side

- Barcode equipment for capturing order and product data
- Module for intermediate storage, assignment of product data to the process, preparation of the delivery note and/or label printing (in the case of full EDI, the data branching EDI-Transfer/Paper-EDI also takes place here).
- Delivery note/label printing module with "EDI mark" function, if necessary, also as downstream print module with this feature.

At receiver's side

- 2D scanner for capturing the 2d-Code (EDI mark).
- Data capture module for recording delivery data with expiry dates/batches/serial numbers, etc.
- Process module for administration of the received delivery data.

3.7 Technical realization

The compilation of the delivery data starts with the "picking". The manufacturer marks his products according to standards, such as ADC or with UDI with the HIBC code, or IFA with PZN or GS1. This is a prerequisite for error-free "picking" before a delivery note with PaperEDI mark can be generated.

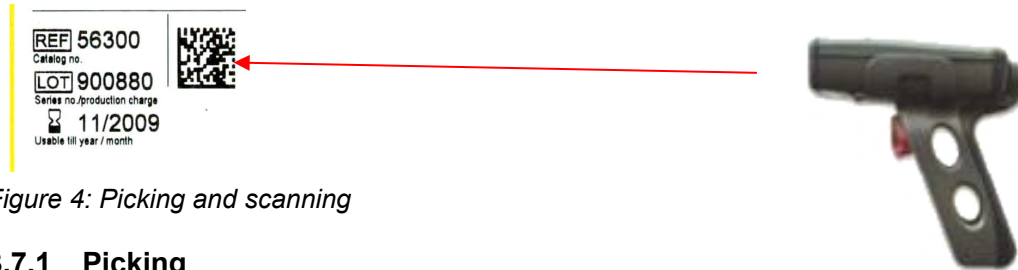

Figure 4: Picking and scanning

3.7.1 Picking

An "EDI mark" shall be filled with accurate data. This is achieved by scanning the products during picking (Fig. 4). In the case of serialized products, each product has to be scanned; in the case of batch products, scanning <product><batch><quantity> is sufficient.

3.7.2 Handling different codes when picking

When picking at different stations in a supply chain, different symbologies and data structures occur. Capturing data from different codes by a scanner and processing different code structures in one system is state of the art. According to ISO 22742 Packaging - Linear & Two-Dimensional Symbologies for Product Packaging and also according to UDI, the 3 most important structures are the syntax with ASC Data Identifiers (ASC DI's), with GS1 Application Identifiers (AI's) and the HIBC structure. As UDI compatible system the IFA CODING SYSTEM is using ASC DI structure fully.

For generation of the pick list by scanning the products, it is not important to which structure the product code is built, the PaperEDI method is harmonizing the structures to one.

3.7.3 Interface from the system to generate PaperEDI

The interface to "PaperEDI" (also to EDI) is in the system where the delivery data is prepared for the delivery note printing (or also invoice), e.g. in the data base where all the packing unit data lay.

These delivery data are provided with the corresponding data identifiers according to ISO/IEC 15418, part ASC in a "PaperEDI" conversion module and embedded into the "Syntax for High Capacity Media" ISO/IEC 15434" or DIN 16598. The content can thus be interpreted by all chain partners in the chain in a standard-compliant and secure manner. In classic "EDI" the data is typically converted into "UN EDIFACT" syntax. There are references and compatibility between the "UN EDIFACT" qualifiers and the ISO/IEC 15418 ASC Data Identifiers. The latter is well suited for 2D symbology and RFID, as the latter has less "overhead", e.g. the actual data volume is smaller and consequently the codes become smaller too.

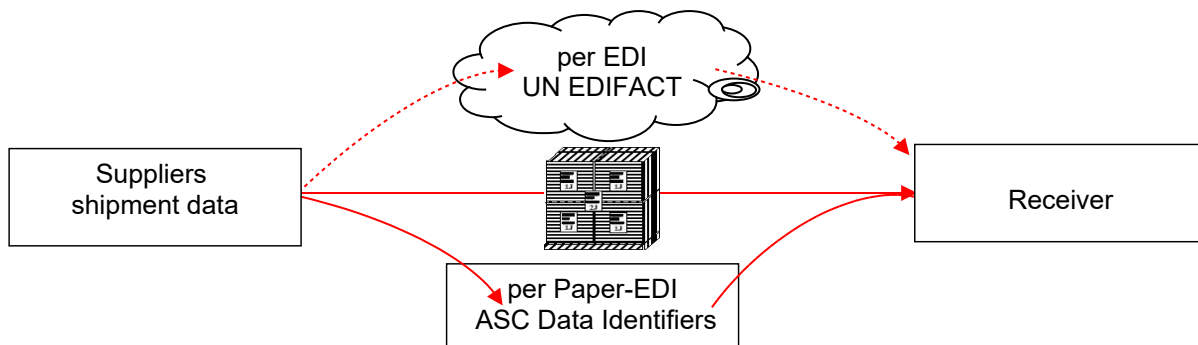

Figure 5: Compatibility of "UN EDIFACT Qualifiers" and "ISO/IEC 15418 ASC Data Identifiers"

The determination of the data elements for PaperEDI is preferably done in accordance with the data elements of a related UN-EDIFACT message.

3.7.4 Steps for the production of a PaperEDI mark

First, the data elements that are to be transferred via "Paper EDI" to be defined in a "Paper EDI agreement" agreed by the parties. These are reflected in the software tool that will automatically generate the EDI mark after receiving the relevant data. If not prepared already the tool will add ASC Data Identifiers to the data elements. By means of data identifier "F" the message will be hierarchically ordered, i.e. for example "all serial numbers under one product number". Additional data compression is an option. Then the message is put into the transfer syntax ISO/IEC 15434 and finally encoded as EDI mark in 2D symbology.

The PaperEDI generation process includes the following steps

- Compile the data elements for an EDI mark and check for consistency with any existing EDI EDIFACT message..
- Add ASC Data Identifiers as prefix to the data elements
- Structure data elements using DI "F" and concatenate them to form a message.
- Embed message in syntax ISO/IEC 15434 or DI 16598 and
- print message as "EDI mark" on delivery note or transport label.

→ Now the data content of the EDI mark with the shipment content data can be captured automatically, securely and at lightning speed at any location, where the shipment occurs.

4 Syntax for PaperEDI

Two options are available as syntax for encoding the "P'EDI data" in 2d symbols:

- 1) Syntax with control characters for multiple formats in one code and for "Full ASCII interfaces":
 - ISO/IEC 15434 Syntax for High Capacity Media
- 2) Keyboard and WEB compatible syntax also for keyboard interfaces:
 - DIN 16598 syntax for keyboard and internet compatible encoding of data elements in machine readable symbols using Data identifiers

4.1 "Syntax for High Capacity Media ISO/IEC 15434 " is used to encode larger volumes of data in a standardized form in 2D code or RFID. The syntax is structured so that one or more message types can be accommodated. The syntax allows use of different formats in one code. Currently, 12 formats are selectable as data structures, including ASC DI's (06), GS1 AI's (05) , UN EDIFACT (04), etc., also free text (07). Each structure has its own format identifier in the syntax, so that the computer logic can apply the respective rule when decoding. In the standard case only one message type is required. For the EDI mark the format identifier "06" is suitable flagging the use of data identifiers. The syntax consists of the "Message Header", followed by the "Format Header" for flagging the embedded data structure and finally the "Format Trailer" at the end of the string. The data elements are separated from each other by "Group Separator" (GS).

Header, Separator and Trailer consist of non-printable control characters of the ASCII list and consequently cannot be entered via keyboard, but expect a "Full ASCII Interface" for generating and entering (alternative option see 4.2).

A data string with start sequence, format identifier, separators and stop characters is composed as follows:

- Start sequence: [] > ^RS
- Format identifier: 06
- Separator: ^GS
- Data element with DI and data value
- Separator: ^GS
- next Data element with DI and data value
- ... etc. until end with the stop sequence with the characters: ^RS ^EO_T.

Data string as an example sequence from start to stop:

[] > ^RS 06 ^GS DI Data ^GS DI Data ^GS DI Data ^EO_T

Illustration of the example sequence, provided with 2 leading data elements:

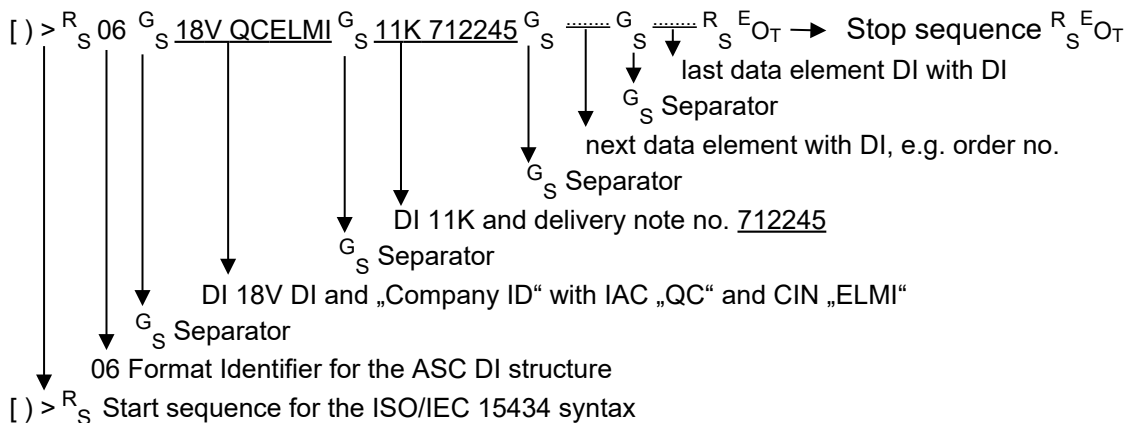

In this form, the data will be encoded in a 2D code:

[] > ^RS 06 ^GS 18VQCCELMI ^GS 11K712245 ^GS Datenelement ^GS Datenelement ^GS usw bis..... ^RS ^EO_T

Note: DATA MATRIX according to ISO/IEC 16022 includes a "macro command", which reduces the start sequence to one command character. In RFID, this is optimized accordingly via the Application Family Identifier (AFI).

4.2 Keyboard and WEB compatible syntax DIN 16598 for „Paper-EDI“

"DIN 16598 Syntax for keyboard and internet compatible coding of data elements in machine readable symbols using data identifiers" is an alternative to ISO/IEC 15434 syntax, which is used when the data is to be transmitted for printing, or after reading the code directly via keyboard or WEB interface, and when only "ASC Data Identifier" format is used in a code.

The system identifier for using ASC DI's is the dot < . >, the separator is the circumflex character < ^ >, a stop character is not required.

A complete data string in this syntax with start, data and separators is composed as follows (vertical representation):

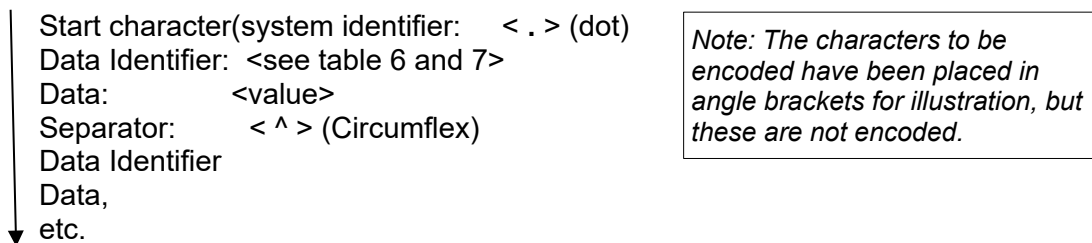

Data string displayed linearly as an example sequence from start to last data element:

<.><DI><DATA<^>DI><DATA<^><DI><DATA<^>.....<DI><DATA><Terminator>

add "end" because the chain of characters may represent a message, an "end" character should be envisaged ? In electronic EDI, there is a "message end" sign...

Illustration of a short example sequence, provided with the example data

Company ID "QCELM I" (DI 18V) and delivery note number "712245" (DI 11K):

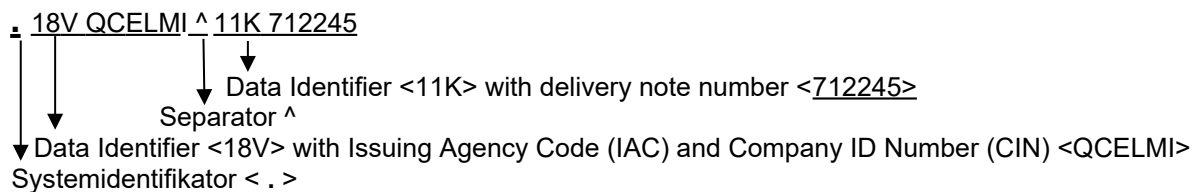

In this form, the data string is placed in a barcode and is also read as it is printed:

.18VQCELM I^11K 712245

Note: For an example of a complete P'EDI message, see section 4.13.

4.3 Data elements for the EDI mark and their data identifiers

For the data elements in an "EDI mark", the "ASC Data Identifiers (DI's)" are selected, which are introduced for both internal and external codes (see section 16-17) and are also used consistently by adjacent industries (electronics, etc.). The Data Identifiers are selected from the list of ASC Data Identifiers ISO/IEC 15418, part "ASC MH10 Data Identifiers".

The following table shows the selection of data data elements and their ASC DIs applying to a delivery note. For other applications additional ASC DIs may apply.

Table 1: Data elements of PaperEDI and associated Data Identifiers

Header data	DI	Sequence (Comma doesn't appear in the code)	X= shall
PIC of the sender of the document	18V	18V, Issuing Agency Code, Company ID	X
Supplier code determined by the customer	V	V, Supplier code	
Customer code determined by the supplier	9V	9V, Customer code	
Document type	12P	See chapter 4.4	X
Version document structure	16S	Actually version „2“	X
Order no. assigned by customer	K	K, Data	
Order reference of supplier	1K	1K, Data	
Transport reference (Licence plate)	J	J, PIC, Tracking ID example JQCELM I952490BT4 optional DIs: 1J bis 4J	
Delivery note Number	11K	11K, Number	X
Delivery note Date	6D..111	6D,YYYYMMDD, 111 (111=ANSI X12.3. code list 374 „Ship Notice/Delivery Note“)	
Shipping Date	6D..011	6D,YYYYMMDD, 011 (011=„Shipped on..“)	
Requested Ship Date	6D..010	6D,YYYYMMDD, 010 (010=Requ. Ship Date)	
Purchase Order Date	6D..004	6D,YYYYMMDD, 004 (004=Order Date)	
Invoice Date	6D..003	6D,YYYYMMDD, 003 (003=Invoice Date)	
Shipment data			
Supplier's article number as on the document, e.g. on the delivery note.	1P	1P, Product ref.	X
Product reference in UDI-DI format for the structures GS1 (GTIN), HIBC, IFA (PPN/PZN) and ISBT	54P	54P, UDI-DI	
Product/Material number assigned by the customer	P	P, Material number	
Line number of the order	4K	4K, Line number	
Expiry date	14D	14D, JJJJMMTT, e.g. 14D20071012	
Charge/Lot number	1T	1T, Charge/Lot	
Serial number	S	S, SN	
Quantity per sales unit	Q	Q, Quantity	
Internet link	33L	Uniform Resource Locator (URL). Character set RFC 1738 (. http://....)	
Patientenreferenz	H...+LK	H, Patient reference, LK (LK=Patient)	
Medical parameter (e.g.	32Q ¹	LOINC Code+Parameter (<i>replaces 11Y</i>)	
Structural control characters			
Symbol number, No. of symbols (pages), Group ID	4F	4F, Symbol number/No. Of symbols / Group ID	
Order DI of the hierarchical tree	F	F ## ## 1 #	

¹„11Y“ is a temporary data identifier until a specific DI is listed in ANSI MH10.8.2.

<i>Table 1 continued</i>		
Other data elements		
Unit price net product	27Q	27Q,value, e.g. 22,80 →27Q22.80 (currency under „12Qxxx“) „.“ dot used as decimal point
Unit price net postage and packing	28Q	28Q,value, e.g. 6.80 → 28Q6.80
Discount in percent	29Q	29Q,value, e.g. 5,5% → 29Q5.5, „.“ dot used as decimal point
VAT in percent	30Q	30Q,value, e.g. 7% (VAT supplement applies to the product if different from the default value under 12Q)

4.4 Document type

The document type is flagged with the data identifier "12P" and is a a mandatory field. Document type options are listed with table 2 plus document no. (The default value is "delivery note": <12PDESADV>.

Table 2: Document types

Document	12P value	Chapter	Related EDI term
Delivery note	DESADV	Main document	DESADV
Invoice	INVOIC	Appendix B	INVOIC
Delivery note and invoice	DESADV/INVOIC	Appendix C	DESADV/INVOIC
Quotation	QUOTES	Appendix D	QUOTES
Order	ORDERS	Appendix E	ORDERS
Order confirmation	ORDRSP	Appendix F	ORDRSP
Consignment stock replenishment	CONORDERS	Appendix G	PROACT
Consignment stock consumption	CONSUM	Appendix J	PROACT
Consignment stock supply	CONDESADV	Appendix H	DESADV
Consignment stock return request	CONBACREQ	Appendix I	
Credit note	INVOIC	Appendix I	INVOIC
Return delivery	DESADV	Appendix J	DESADV

4.5 PIC of the sender

Within paper EDI, globally unique number ranges are preferably used, which are formed by prefixing with a unique party identification code (PIC) according to ISO/IEC 15459-2.

A PIC consists of the code of the Issuing Agency Code (IAC), followed by the registered Company Identification Number (CIN), or Labeler Identification Code (LIC). Product codes with UDI fulfill the conditions of uniqueness.

Each vendor as sender of a PaperEDI document requires a PIC as a unique sender identifier, which is flagged by the DI "18V" in the header as a mandatory field.

In addition, a PIC is also used as a prefix for the shipping unit and for the group ID per page or symbol. These PICs can be the same as the PIC of the sender, or also other PICs.

Some examples of PIC's from different Issuing Agencies:

- HIBCC: PIC is formed by IAC "RH "+LIC. Example: "RHH999"
- E-D-C: PIC is formed by IAC "QC"+CIN. Example: "QCELM1"
- IFA Coding System: PIC is formed by IAC „PP“ + CIN. Example „PP 12345“
- GS1: Company ID is the „ILN2“ and part of the GTIN.
- D&B: PIC is formed by IAC "UN" + 9 digit DUNS number.

4.6 Supplier product code

Paper EDI always carries the supplier's part numbers with DI "1P" and may additionally carry a barcoded product reference.

This article number is managed by the supplier and is indicated on the orders and on delivery notes. The recipient uses these numbers to match the data on the delivery note (PaperEDI) with the order data.

4.7 UDI Bar coded product reference on the product and within PaperEDI

On the product/package subject to UDI, the UDI-DI and UDI-PI data elements will be encoded in an UDI-accredited barcode structure like GS1, HIBC, ISBT, PZN/PPN.

Within a EDI message the UDI-DI data element will be quoted by the ASC DI "54P" (see chapter 3.5.2.c) but the UDI-PI data elements by the relevant ASC DIs, like "1T" for LOT or "S" for SN., "16D" for manufacturing date, etc.

Table 3 shows the relationship of UDI-DI values in Barcode according to a selected Issuing Agency and the same value in Paper-EDI applied with to DI "54P".

Table 3: Relationship UDI-DI value encoded in Barcode format on the product or package and carried with PaperEDI applied with the harmonized UDI-DI format defined by ASC DI "54P"

Barcode structure	Barcoded UDI-DI data on product	Example of a UDI-DI for barcode	Representation of a UDI-DI in P'EDI with DI "54P"
GS1	GTIN 14 consisting of: <ul style="list-style-type: none"> • Location code • Product reference • Check digit 	(01) 01111012345622	54P 01111012345622 (A GTIN 13 will be completed with leading zero to 14 digits)
HIBC	HIBC Primary code with the data: <ul style="list-style-type: none"> • „+“ (System ID) • LIC (4 characters) • Product code (1-18an) • Packaging index (0-8) 	+H9991234567890 <ul style="list-style-type: none"> • „+“ • LIC: H999 • Product code: 123456789 • Packaging index: 0 	54P H9991234567890
PZN/PPN	PZN in Code 39 flag „-“ in 2D with DI 9N for PPN PPN with PZN consists of: <ul style="list-style-type: none"> • „11“ for a „PZN“ • PZN • 2 check digits 	-01234562 9N 110123456224	54P 110123456224 (always applied with 2 PPN check digits)
PZN in GS1	GTIN with the data: <ul style="list-style-type: none"> • 04150: ILN for PZN • PZN • GTIN check digit 	(01) 04150012345623 GTIN with the fields <ul style="list-style-type: none"> • 04150: ID for PZN • PZN: 01234562 • GTIN Check digit: 3 	54P 04150012345623

4.8 Patient reference and medical parameter

Specific product data transmitted via P'EDI may require a patient reference and type of work if made exclusively for a specific patient. The data elements "Patient reference" and "Medical parameter" are introduced for this purpose.

An example of use is the individual fabrication of customized dental prostheses, where the

patient reference is included with the order, optional medical parameters are specified by LOINC code (see chapter 1 Terms, chapter 3.5.2, c), chapter 4.1, table 1) .

4.9 Distribution of data information to multiple code symbols

Data information can be distributed over several symbols. This can be the case, if delivery notes amount more than one page or for symbol size reasons.

The data identifier "4F" is used to define the symbol number and to link to the belonging other symbols.

Data Identifier „4F“

The data identifier "4F" leads the symbol number, the number of symbols that belong to a delivery note, as well as a common group ID that is the same for all pages to ensure that they belong together.

Group ID

The group ID represents a unique reference and is the same for all pages. The group ID is headed by a PIC, e.g. QCELM102030. An existing unique reference, such as a delivery note number, can also be used as a reference after the PIC. The group ID is optional, but always helpful when different page sets that do not belong together could be mixed.

Sequence after DI „4F“ in detail

The sequence determined by the DI is:

<DI (4F)><Symbol no.><Separator><No. of symbols<Separator><Group ID>

The separator character inside of the sequence is the slash (/). Even if the number of symbols between 2 separators is not stated, the separators will be printed. If no data follows a separator, this separator can be omitted.

Use cases for determining the number of symbols

a) Number of symbols is already known when generating the first symbol and is carried along from the first symbol. In this case all elements of the sequence can be filled:

<4F1/4/QCELM102030>.

b) Number of symbols is known only when printing the last symbol.

If the total number of symbols is not yet known when printing the first symbol, but can only be generated when printing the last symbol, this information remains empty

<4F1//QCELM102030> ,

but will be at the last page:

<4F4/4/QCELM102030>.

c) The use of a group ID is optional but always recommended.

In the following table you will find examples of a 4-page or 4-symbol sequence, with common group ID "QCELM148252", which includes the PIC "QCELM1" and the delivery note number "4852":

Table 4: Examples of 4F sequences for multiple symbols

4F + parameter data	description
4F1	This is the first symbol of a number of symbols, number of symbols not yet known, no group ID".
4F1/4	This is the first of 4 symbols without specifying a "Group ID"
4F1/4/QCELM148252	This the first symbol of 4 symbols with group ID "QCELM148252".
4F1//QCELM148252	This is symbol 1 of a yet unknown number of symbols with Group ID "QCELM148252".
4F4/4/QCELM148252	This is symbol 4 of 4 with group ID "QCELM148252".

If the number of symbols is 1, the sequence specification can be omitted completely. However, the indication that it is 1 of 1 page is allowed, e.g. "4F1/1/QCELM148252". The DI "4F" is always the first DI of each symbol.

From the second page onwards, it is sufficient if the company ID of the sender after DI "18V" is given as header data <18V><QCELM1>. The structure always starts at the same root element as on the first page.

A typical start from the second page is:

DI	Parameter data	Description
4F	2/4/QCELM148252	Page 2 of 4 pages and Group ID
F	01001S	Structure header of the shipment. Only CompanyID follows, because full header is already on page 1.
18V	QCELM1	Company ID of the sender
F	02011I	Structure header of the article level
1P	12345	First article of page 2

However, it is also allowed to repeat all header data in each symbol.

4.10 Hierarchy of data in a PaperEDI message

In a PaperEDI interchange message the data elements are grouped into a tree structure similar to Electronic Data Communication (EDI). The header data is at the top, followed by the product codes and then the variables like batch/serial number, etc.

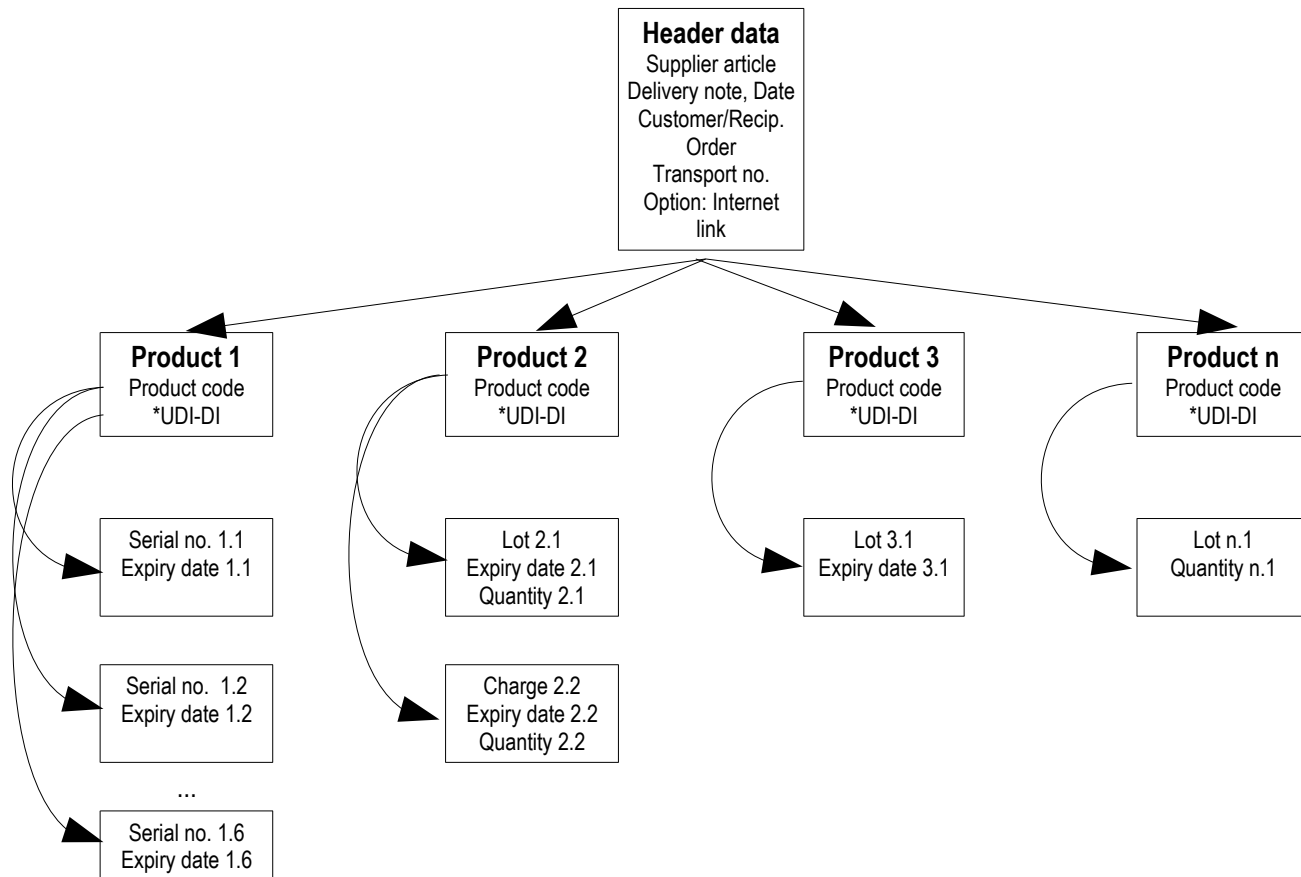

Figure 6: Data hierarchy within a PaperEDI message construct.

*Note: UDI stands for “Unique Device Identifier, as synonym for a product code

The logical grouping of the data elements is done by means of data identifier "F".

4.10.1 Data Identifier „F“ for hierarchical structuring and optimization of the messages

The hierarchical relationship between the data elements is established by the data identifier "F". The DI "F" leads a sequence, which contains the logic of the affiliation of the data elements. The basic principle of this logic is: Each hierarchy sequence "F" has an alphanumeric hierarchy ID at position 2-3. The affiliation is achieved by repeating this ID at position 4-5 of the "F sequence" (Parent ID) for all subordinate levels. The levels get an additionally "ID code" to explain whether it is header data, product data, batch/serial number data.

The "F sequence" consists of 7-8 characters each in the following structure:

F	###	#	#	Description	Länge
			#	Hierarchy level code, see table 5	1-2
			#	"Child Code" 0 or 1. If 0 there are no child levels, if 1: YES.	1
		##		"Parent ID" - identifier of the parent hierarchy ID	2
	##			Hierarchy ID - identifier for the given level. This consists of 2 characters with character set as numbers or capital letters.	2
F				Data Identifier "F"	1

Table 5: ID codes of the hierarchy levels

Level	ID	Description
Delivery/ Shipment	S	Level Reference data for delivery Delivery note no., supplier no. etc.
Product/ Item	I	Product level Packaging unit/ Stock keeping Unit (SKU) identification data
Serial / Lot	X	Level product data with batch, expiry date, quantity, serial number, ...
Options		
Order	O	Reference data for the order, if more then one in one delivery
Pack	P	Packed level/Over pack

Note: These levels of Table 5 are an extract and correspond to the most common practice. For further ID's for hierarchy levels see ASC X12 Data Element Directory.

4.10.1.1 The logic of the hierarchy

The logical connection of the "F sequences" and underlying data fields to each other is achieved by placing the ID number of the parent level (Parent ID) in the associated level. In addition, there are the indications whether a level follows and what kind of level it is.

First level header data with Hirarchy ID "01"

F	##	##	#	#	Description
				S	Code of the hierarchy level, here ID "S" for shipment
			1		"Child Code" 0 or 1. With „0“ no assigned field follows, here a field follows, thus "1".
		00			no "Parent ID" – No superordinate hierarchy: „00“
		01			Hierarchy ID – Number for the field in question, start with "01".
F					Data Identifier "F"

Level product data type 1 with Hierarchy ID 02

F	##	##	#	#	Description
				I	Code of the hierarchy level, here ID "I" for product (item)
			1		"Child Code" 0 or 1. If 0 there is no associated field, here „1“ (YES there is one).
		01			"Parent ID" – Number of the parent hierarchy ID, here "01"
		02			Hierarchy ID - number for the field in question, here „02“
F					Data Identifier "F"

Ebene 2 Lot/SN Typ 2 with Hierarchy ID 03

F	##	##	#	#	Description
				X	Code of the hierarchy level, here ID "X" for level lot/serial number
			0		"Child Code" 0 or 1. If 0, no child level follows.
		02			"Parent ID" - number of the parent hierarchy ID, here "02"
		03			Hierarchy ID - number for the field in question, incremented here „03“
F					Data Identifier "F"

etc..

4.10.1.2 Graphical representation of the logic

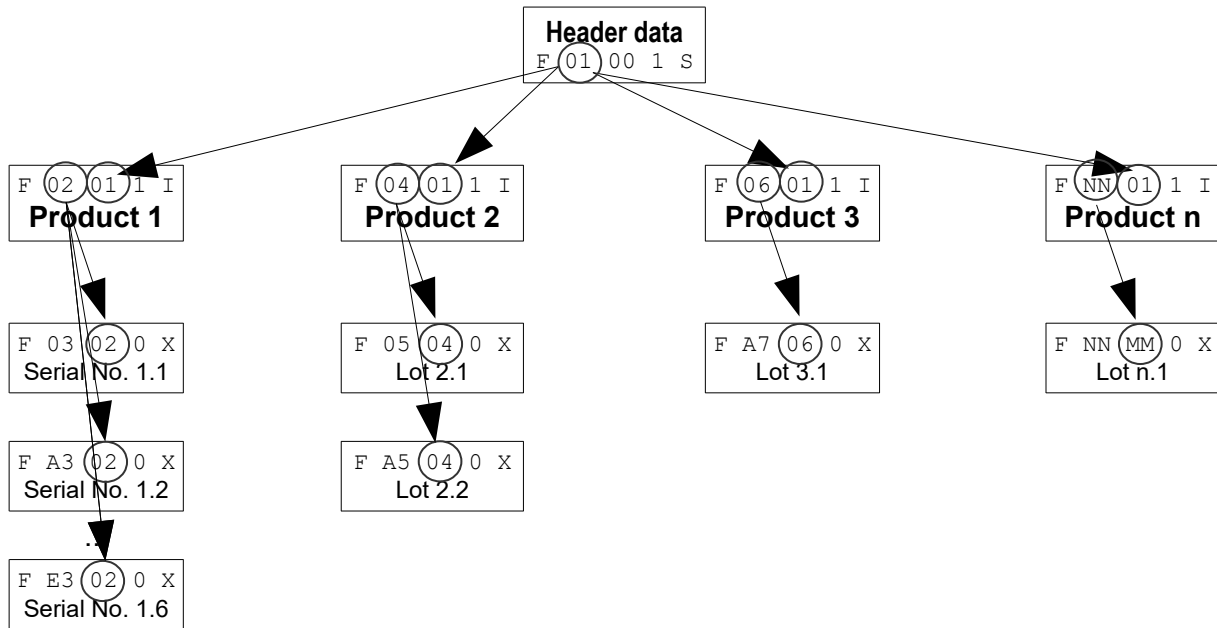

Figure 7: Graphical representation of the logic to the layers

4.10.2 Structure of a delivery message before grouping

The structure of a complete delivery message for accommodation in an "EDI mark" will be illustrated on the basis of example data of page 1 of a delivery note. This delivery will consist of different products, which are provided with barcode reference, serial number or Lot and expiry date and shipped in a transport unit applied with an ISO/IEC 15459-1 License Plate. The header data are consisting of the data elements of table 6:

Table 6: Header data

Data element		Data content	DI	Data applied with DI
Symbol information		Symbol/No. of/ Group ID	4F	4F1/4/QCELM148252
Data information	Hierarchy level	<i>Hierarchy ID: 01</i>		
Sender	S	PIC	18V	18VQCELM1
Document type	S	Delivery note	12P	12PDESADV
Document version	S	Version 2	16S	16S2
Delivery note no.	S	712245	11K	11K712245
Supplier	S	ABT	V	VABT
Customer order	S	3087627	K	K3087627
Transport no.	S	PIC+67814MZ	J	JQCELM167814MZ

The header data is followed by the product data

Table 7: Product data

Data element	Hierarchy ID	Data content	DI	Data applied with DI
	Item	<i>Hierarchy ID: 02</i>		
Product type 1, 6 pcs, 6 Serialno.	I	321MED	1P	1P321MED
UDI-DI with Packaging Index 1	I	H999321MED1	54P	54PH999321MED1
	Ser/Lot	<i>Hierarchy ID: 03, A3-C3</i>		
Serial numbers	X	4561-4566	S	S4561, S4562, S4563, usw.
Expiry date	X	2030-12-31	14D	14D20301231
	Item	<i>Hierarchy ID: 04</i>		
Product type 2, 20 pcs., 1 Lot, Expiry date	I	23443366	1P	1PQC23443366
UDI-DI	I	H999234433661	54P	54PH999234433661
	SN/Lot	<i>Hierarchy ID: 05, A5</i>		
Lot 2a	X	0701271	1T	1T0701271
Quantity	X	20	Q	Q20
Expiry date	X	2030-06-31	14D	14D20300630
Lot 2b	X	0753634	1T	1T0753634
Quantity	X	55	Q	Q55
Expiry date	X	2030-06-31	14D	14D20300331
	Item	<i>Hierarchy ID: 06</i>		
Product type 3, 10 pcs., 1 Lot	I	23443366	1P	1P32563381
UDI-DI	I	01234567890128	54P	54P01234567890128
	Item	<i>Hierarchy ID: A7</i>		
Lot	I	0701023	1T	1T0701023
Quantity	I	10	Q	Q10

4.10.3 Compaction

Due to the limitation in the data capacity of one single 2D code, the following optimization can be checked.

- a) Only the fields and data that are significant should be coded, no empty fields without data for batches (1T), expiry dates (14D), etc.
- b) Standard values
If a field has the default value, this field can be omitted, e.g.:
4F1/1 for only one side
Q1 for quantity 1
- c) On subsequent pages, header data do not have to be repeated, such as delivery note number.
But even if no header data is included, the segment "F01001S" must still be coded.

For optimization rules see chapter 4.10.4

4.10.3.1 Grouping the data into the hierarchy

The hierarchy sequence with data identifier "F" is placed in front of the grouped levels. This provides for the togetherness and groupings.

The following example contains numbered "F sequences" for grouping the data of 3 product groups, which in turn are provided with different serial numbers, batches and/or expiry dates. F-sequences with letters as hierarchy ID (e.g. "A3", "B3", "C3", ...) can be omitted by the optimization rules (chapter 4.10.4).

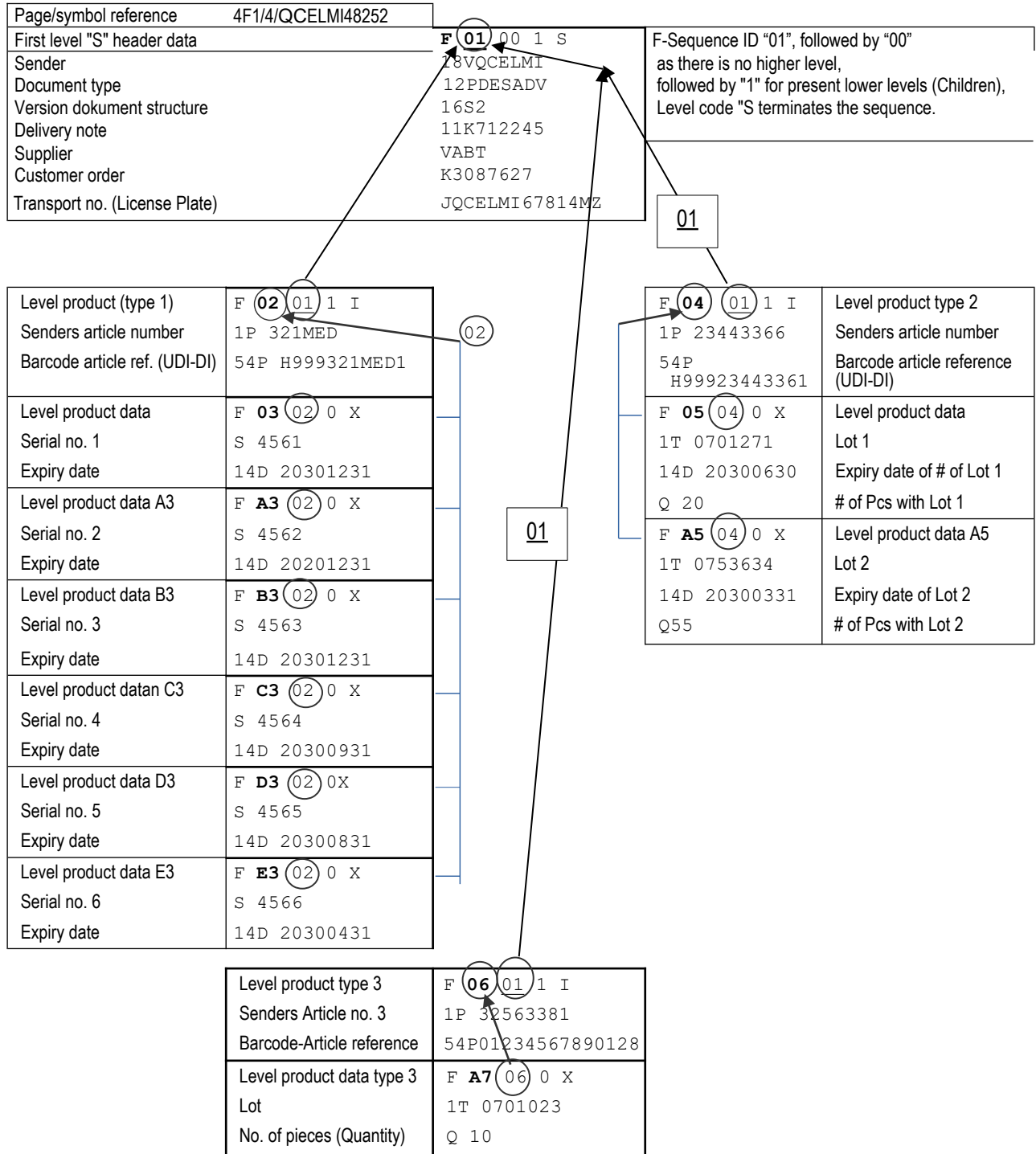

Figure 8: Sample data grouped and embedded in the hierarchy

4.10.4 Optimization rules for "F-sequences"

The data identifier "F" is used not only to assign the fields in the hierarchy, but also for optimization. For this purpose 3 rules follow below. We start with an "I" segment and one or more "X" segments as „Children".

- Rule 1: Consolidate identical field data
All fields that occur in all "X" segments and have identical data can be omitted in all "X" segments once they have been written to the "I" segment.
- Rule 2: Avoid empty X segment
If only one "X" segment exists and becomes empty due to the previous action to rule 1 or only the quantity remains, the segment is omitted. The sum of the quantities is written to the I segment if it is not 1.
- Rule 3: Implicit segments
If several "I" or "X" segments have no "children" (after applying previous rules 1 and 2), they can be written into a common segment. The second condition for optimization is that all these combined segments start with the same Data Identifier (DI "S" in example 2.10.3, segment F03020X).

This rule can also be formulated as follows:

If the first field type (DI) is repeated in a segment, another segment with the same segment type is implicitly opened.

Examples of the individual rules in relation to figure 8:

- R1: Consolidate identical field data
 - Identical expiry dates of segments 03 to E3.
 - Product properties of segment A7 (if there is only one product, these are always the same for all)
- R2: Delete empty X segment
 - Segment A7 has become empty due to R1
- R3: Implicit segments
 - All repeated X segment boundaries: A3-E3, A5

The following table shows the example with the applied optimizations.

Table 8: Data elements of fig. 8 prior to concatenation

Page/symbol reference	4F1/4/ QCELM I48252
Level header data	F 01 00 1 S
Sender	18VQCELM I
Document type	12PDESADV
Version doc.structure	16S2
Delivery note	11K712245
Supplier	VABT
Customer order	K3087627
Transport no.	JQCELM I67814MZ

Level product	F 02 <u>01</u> 1 I	(Note 1)	F 04 <u>01</u> 1 I	Level product 2
Senders article no.	1P 321MED		1P 23443366	Senders article no.
BC article ref. (UDI-DI)	54P H999321MED1		54P H99923443361	Barcode article ref.(UDI)
Expiry date	14D 20301231	(Note 2)	F 05 04 0 X	Level product data
Level product data	F 03 02 0 X		1T 0701271	Lot 1
Serial no. 1	S 4561		14D 20300630	Expiry date of Lot 1
Serial no. 2	S 4562		Q 20	No- of pcs. With Lot 1
Serial no. 3	S 4563		1T 0753634	Lot 2
Serial no. 4	S 4564		14D 20300331	Expiry date of Lot 2
Serial no. 5	S 4565		Q 55	No- of pcs. with Lot 2
Serial no. 6	S 4566			

Level product 3	F 06 <u>01</u> 0 I	(Note 3)
Senders article no. 3	1P 32563381	
Barcode article reference (UDI-DI)	54P 01234567890128	
Lot	1T 0701023	
No- of pcs. (Quantity)	Q 10	

Note 1: The expiration date was the same for all products and could thus be moved one level higher according to Rule 1.

Note 2: Since the X levels always start with an S, the repeated level indication can be omitted.

Note 3: Rule 1 moves all properties from the X to the I level. As a result, the X segment becomes empty and can be dropped according to rule 2. The I level has no more children and the child indicator is set to 0.

4.11 Concatenation of data segments before embedding in the syntax ISO/IEC 15434

Prior to encoding the data segments will be concatenated one after other distinguished by the separator "G_s". Concatenating the data elements of table 8 is resulting in the following data string being ready for completion:

```
4F1/4/QCELM I48252G_sF01001SG_s18VQCELM IG_s12PDESADVG_s16S2G_s11K712245G_sVABTG_s
K3087627G_s JQCELM I67814MZG_sF02011IG_s1P321MEDG_s54PH999321MED1G_s14D20301231G_s
F03020XG_sS4561G_s S4562G_sS4563G_sS4564G_sS4565G_sS4566G_sF04011IG_s
1P23443366G_s54PH999234433661G_sF05040XG_s1T0701271G_s14D20300630G_sQ20G_s1T0753634
G_s 14D20300331G_sQ55G_sF06010IG_s 1P32563381G_s 54P01234567890128G_s1T0701023G_sQ10
```

Now the message is ready to be embedded in the syntax ISO/IEC 15434 by adding the start and stop sequences (see 4.12).

4.12 Embedding of the message in ISO/IEC 15434 and representation as Data Matrix

Now, the start and stop sequences will be added to the prepared data string:

Start sequence $[] >^R_S$

Format indicator "06" for the DI structure

Group separator " G_S "

Stop sequence " R_S " und " E_O_T " at the end .

With this, the data string is finally ready for printing in a code, here Data Matrix:

<pre>[] >^R_S 06^G_S 4F1/4/QCELM I48252^G_S F01001S^G_S 18VQCELM I^G_S 12PDESADV^G_S 16S2^G_S 11K712245^G_S VABT^G_S K3087627^G_S JQCELM I67814MZ^G_S F02011I^G_S 1P321MED^G_S 54PH999321MED1^G_S 14D20301231^G_S F03020X^G_S S4561^G_S S4562^G_S S4563^G_S S4564^G_S S4565^G_S S4566 ^G_S F04011I^G_S 1P23443366^G_S 54PH999234433661^G_S F05040X^G_S 1T0701271^G_S 14D20300630^G_S Q20^G_S 1T0753634^G_S 14D20300331^G_S Q55^G_S F06010I^G_S 1P32563381^G_S 54P01234567890128^G_S 1T0701023^G_S Q10^R_S E_O_T</pre>	
---	---

Figure 9: Data Matrix code with PaperEDI content structured according to syntax ISO/IEC 15434

4.13 Concatenation of data segments and embedding in syntax DIN 16598

Prior to encoding the data segments will be concatenated one after the other distinguished by the separator "^" (circumflex).

Then the system identifier "." (Dot) will be add to the string as start character. There are no stop character or control characters necessary, this already results in the data string ready for encoding in the 2D code:

<pre>.4F1/4/ QCELM I48252^F01001S^18VQCELM I^12PDESADV^16S2^11K712245^VABT^K 3087627^JQCELM I67814MZ^F02011I^1P321MED^54PH999321MED1^14D203 01231^F03020X^S4561^S4562^S4563^S4564^S4565^S4566^F04011I^1P2 3443366^54PH999234433661^F05040X^1T0701271^14D20300630^Q20^1T 0753634^14D20300331^Q55^F06010I^1P32563381^54P01234567890128^ 1T0701023^Q10</pre>	
---	---

Figure 9b: PaperEDI data of table 8, same as Fig. 9, but embedded in keyboard and WEB compatible syntax DIN 16598 and also encoded in Data Matrix

4.14 Inserting the PaperEDI symbol into the delivery note

The Paper-EDI symbol(s) will now be inserted into the delivery note, sample see Fig.10.

To: Dr. Med. Dent Alois Bernd White street 12 99999 Whiton		Date: 21.12.20 Your order: K3087627 Your supplier reference: VABT Tracking #: QCELM167814MZ Page/symbol: 1 of 4		 
Delivery note no.: 712245				
	Article no.	pcs.	Article description	
1	321MED	6	Implant screws (sterile) Expiry date: 31.12.30 Serial no's: 4561, 4562, 4563, 4564, 5565, 4566	
2	23443366	20	Wound bandage (sterile) Expiry date: 30.6.30 Lot: 0701271	
		55	Wound bandage (sterile) Expiry: 31.3.30 Lot: 0753634	
3	32563381	10	Fastening clips, Lot: 0701023	

Figure 10: Sample delivery note applied with Paper-EDI

4.15 Reading the example PaperEDI

E.g. with the tool Elmi-ScanLink the PaperEDI symbol can be read and the data can be analyzed, displayed and transferred to the ERP system.

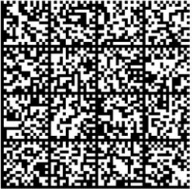
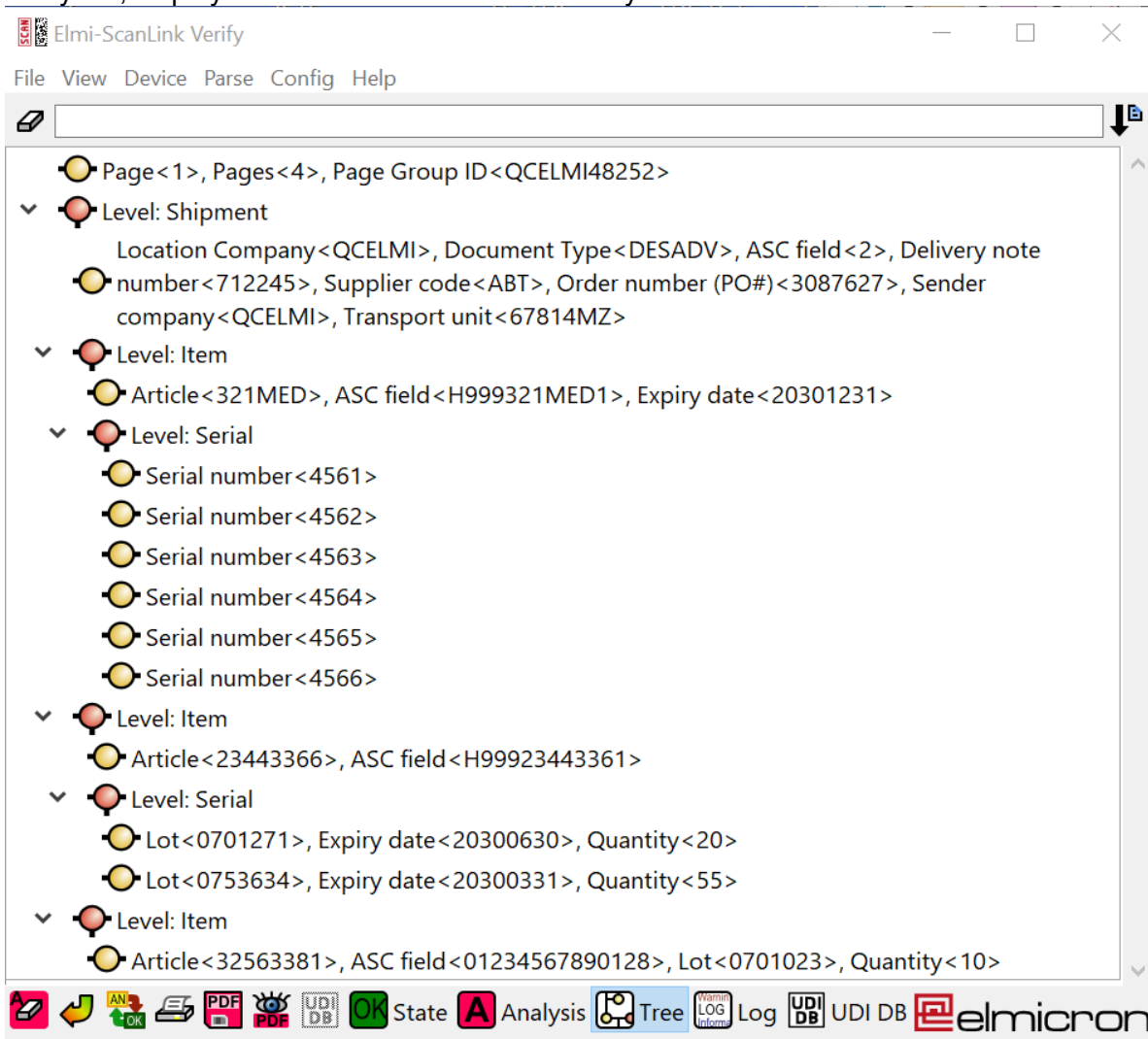

Figure 11: Tree representation of the scanned PaperEDI mark via Elmi-ScanLink

A detailed representation is shown in the analysis view, which is shown in the following images. It also shows how layers omitted by the optimization are restored by implicit layers.

	ID	Data	Comment
Scan no 1. with Elmican ECR14 POS - USB POS			
Symbology	d1	Datamatrix	Symbology type Datamatrix passed by reader
Raw data		[] ><rs>06<gs>4F1/4/QCELM148252<gs>F01001S<gs>18VQCELM1<gs>12PDESADV<gs>16S2<gs>11K712245<gs>VABT<gs>K3087627<gs>JQCELM167814MZ<gs>F02011I<gs>1P321MED<gs>54PH999321MED1<gs>14D20301231<gs>F03020X<gs>S4561<gs>S4562<gs>S4563<gs>S4564<gs>S4565<gs>S4566<gs>F04011I<gs>1P23443366<gs>54PH99923443361<gs>F05040X<gs>1T0701271<gs>14D20300630<gs>Q20<gs>1T0753634<gs>14D20300331<gs>Q55<gs>F06010I<gs>1P32563381<gs>54P01234567890128<gs>1T0701023<gs>Q10<rs><eot>	
Structure type		ADC	ISO/IEC 15434 container
ADC format type	[] ><rs>	06	ADC format # 1 of type ASC: ANS MH10.8.2 DI
ADC field separator		<gs>	
Page	4F	1	
Pages	/	4	Page 1 of 4 pages
Page Group ID	/	QCELM148252	
Level	F	01001S	Level Shipment Interpreted data: ID 01 Parent 00 Child 1 Level S
Location Company	18V	QCELM1	ELMICRON Issuing Agency: Eurodata Council
Document Type	12P	DESADV	
ASC field	16S	2	ASC DI '16S' without interpretation
Delivery note number	11K	712245	
Supplier code	V	ABT	
Order number (PO#)	K	3087627	
Sender company	J	QCELM1	Multi Industry Transport Label ISO/IEC15459: Transport unit ELMICRON Issuing Agency: Eurodata Council
Transport unit		67814MZ	
Level	F	02011I	Level Item Interpreted data: ID 02 Parent 01 Child 1 Level I
Article	1P	321MED	
ASC field	54P	H999321MED1	ASC DI '54P' without interpretation
Expiry date	14D	20301231	Interpreted data: 2030-12-31
Level	F	03020X	Level Serial Interpreted data: ID 03 Parent 02 Child 0 Level X
Serial number	S	4561	
Level		%	Implicit level due to repetition of DI <S> Interpreted data: ID 03.1 Parent 02 Child 0 Level X
Serial number	S	4562	

Fig. 12, part 1 Analysis view of the example continued with part 2 below

Figure 12, part 2: Continued analysis view of the example

Level		%	Implicit level due to repetition of DI <S> Interpreted data: ID 03.2 Parent 02 Child 0 Level X
Serial number	S	4563	
Level		%	Implicit level due to repetition of DI <S> Interpreted data: ID 03.3 Parent 02 Child 0 Level X
Serial number	S	4564	
Level		%	Implicit level due to repetition of DI <S> Interpreted data: ID 03.4 Parent 02 Child 0 Level X
Serial number	S	4565	
Level		%	Implicit level due to repetition of DI <S> Interpreted data: ID 03.5 Parent 02 Child 0 Level X
Serial number	S	4566	
Level	F	04011I	Level Item Interpreted data: ID 04 Parent 01 Child 1 Level I
Article	1P	23443366	
ASC field	54P	H99923443361	ASC DI '54P' without interpretation
Level	F	05040X	Level Serial Interpreted data: ID 05 Parent 04 Child 0 Level X
Lot	1T	0701271	
Expiry date	14D	20300630	Interpreted data: 2030-06-30
Quantity	Q	20	
Level		%	Implicit level due to repetition of DI <1T> Interpreted data: ID 05.1 Parent 04 Child 0 Level X
Lot	1T	0753634	
Expiry date	14D	20300331	Interpreted data: 2030-03-31
Quantity	Q	55	
Level	F	06010I	Level Item Interpreted data: ID 06 Parent 01 Child 0 Level I
Article	1P	32563381	
ASC field	54P	01234567890128	ASC DI '54P' without interpretation
Lot	1T	0701023	
Quantity	Q	10	
ADC format trailer		<rs>	
ADC End		<eot>	
Result of last scan			
Resume			ADC-Sequence: Total: 4, Scanned: 1

4.16 National special characters (tremas)

National special characters should not appear in PaperEDI. But recently examples with tremas in Lot numbers appeared. Therefore, a sample code with an tremast in the Lot number is provided for test purposes.

Technically, the symbology Data Matrix uses the code page ISO-Latin-1 as standard. Other code pages (like UTF-8) are possible via ECI (Extended Channel Interpretation).

Table 9 includes the tremas character “Ä” in field LOT.

Table 9: Example of an EDI mark with character (Ä) in the lot segment

Data segment	DI	Value
Level Header data	F	01 00 1 S
Sender	18V	QCELM I
Document type	12P	DESADV
Version Doc. structure	16S	2
Delivery note	11K	712245
Level product	F	02 01 0 I
Suppliers article number	1P	321MED
Lot	1T	Ändern

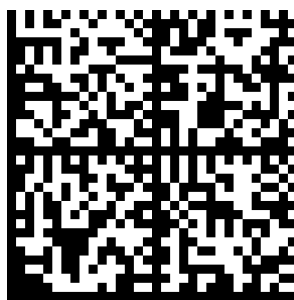

Figure 13, Data of table 9 encoded in Data Matrix

The DataMatrix in the table contains in the field "LOT" the data element with character "Ä": : "Ändern". The character "Ä" is coded in the Data Matrix as "<196>dern". When reading, this data element is represented according to the code page, namely again as "Ändern".

Appendix A: Compatibility with previous versions

The current version can be identified by the version of the document structure in the header data. The current version contains "16S2" for version 2 (since 2020-12-21) in the first header. For previous versions the version no. is missing or set to 1.

A.1: Use of DI "13Q" for page/symbol references

Since 2012, Data Identifier "4F" is available for linking multiple symbols, as introduced in chapter 4.7. Before that, the DI "13Q" was used, which was for counting packages, but this is no longer recommended.

The differences between DI "4F" and DI „13Q“ are summarized in the following Table:

Table 10: DI „4F“ versus predecessor „13Q“

	with DI "4F"		with DI "13Q"		Remark
	Syntax	Example	Syntax	Example	
DI location	Prior to "F01001S"	4F2 F01001S	after "F01001S"	F01001S 13Q2/4	"13Q" in the header after "F"
Page only	4F<page/symbol>	4F2	13Q<page/symbol>/X	13Q2/X	"X" as placeholder for unknown page
Page and # of pages	4F<page>/<pages>	4F2/4	13Q<page>/<pages>	13Q2/4	
Group ID	4F<page>/<# of pages>/<GroupID>	4F2/4/RHELM101485	13Q<page>/<# of p.> 18V<Company ID> 11K<# Delivery note>	13Q2/4 18VRHELM I 11K01485	In each code also repeat delivery note number.

A.2: Use/replacement of the "Issuing Agency Code (IAC)" of EHIBCC "LH"

In the course of the globalization of UDI, the registry for "Labeler Identification Codes (LIC)" was also concentrated on one issuing agency, namely HIBCC.org. This has the IAC "RH". The IAC "LH" should be replaced by the IAC "RH".

Old documents and systems may still use "LH".

In version 2 of the specification, the (E)HIBCC IAC code plays a minor role anyway, as it may only appear in the header of the consignor number. By using DI „54P“ for UDI-DIs, no IAC is required any longer.

A.3: From product code/dealer number to sender item number and UDI barcode reference

In structure version 2 (2020-12-21), article data is represented by sender article number and UDI-DI barcode reference. This replaces the previous distinction between manufacturer products/merchandise and barcode types HIBC/GS1/PPN/PZN.

In structure version 1 the representation differed depending on the barcode type and dealer's own product references.

Table 11: Product codes structure version 1 versus version 2

Barcode ▼	Supplier/manufacturer product or trader's product reference ▼	PaperEDI Version 1 ▼	PaperEDI Version 2 ▼
HIBC Barcode Data: + H787106081090 consisting of the data: <ul style="list-style-type: none"> • LIC: H787 • Product code: 10608109 • packaging index /Unit of measure: 0 	Product from the manufacturer equal as from sender REF: 10608109 same as bar coded-product code	1P 10608109 26Q 0	1P 10608109 54P H787106081090
	Trader's products Trader order no.: 400303	25P LHH78710608109 26Q 0 31P 400301 oder 25P RHH78710608109 26Q 0 31P 400301	1P 400301 54P H787106081090
GS1 – GTIN Barcode Data: (01) 00699073000842	Supplier/Manufacturer REF: 400302	8P 0100699073000842 1P 400302	1P 400302 54P 0100699073000842
	Trader's products Trader order no.: 400303	8P 0100699073000842 31P 400303	1P 400303 54P 0100699073000842
PZN/PPN Barcode Data: 9N 111234567842	Supplier/Manufacturer REF: 400304	9N 111234567842 1P 400304	1P 400304 54P 111234567842
	Trader's products Trader order no.: 400305	9N 111234567842 31P 400305	1P 400305 54P 111234567842

Table 11 presents the migration from version 1 to 2 systematically. The columns are explained in the following sub-chapters of A.3.

A.3.1 Barcode type

In the first column of fig. 8, a distinction is made between the barcode systems HIBC, GS1 and PZN/PPN. In the case of HIBC, the bar code reference breaks down into its components LIC (Label Issuer Code), Product Code and Packaging Index (Unit of Measure, UoM).

A.3.2 Manufacturer product or the trader's reference

In the second column, a distinction is made in each case as to whether the item is a manufacturers product or a merchandise item with trader's reference.

In case of a product with manufacturer's reference and HIBC:

- The LIC of the product equal to the sender's identifier of the Paper-EDI header with IAC "LH" or "RH".
- The REF number is equal to the HIBC product code field.
For merchandise with trader's ref. this fixed assignment is not given as above.

However, for merchandise, paper EDI can carry both the manufacturer's purchase order number and the purchase order number of the trader sending the products.

A.3.3 PaperEDI Version 1

Version 1 was focused on the barcode references, so the barcode information came first.

For traded goods, the trader article number is always flagged by DI "31P". This is also the only information if no barcode data is available. Then the barcode information with DIs 25P/26Q/8P/9N are not present.

In the HIBC case, the specification differs in two respects:

- For manufacturer's article only the REF number is coded with 1P. As mentioned before, in the header the sender ID "18V" must be equal to the barcode LIC number (with prefix RH or LH).
- For trader's references DI "25P" plus "LH" or "RH" plus LIC plus REF number applies.
- The barcode packing index is coded with DI 26Q. If this information is missing, the packaging index = 1.

For GS1 and PZN/PPN barcode references the respective DI's 8P and 9N are used in PaperEDI, which precisely index these barcode structures.

A.3.4 PaperEDI Version 2

The properties of the PaperEDI structure type 2 are described in the main part of the document. Version 2 does not differentiate by barcode types, nor by manufacturer/retailer article numbers. Therefore DI 1P is used for sender's article numbers and in case of UDI DI 54P, the product/article no. is equal to the UDI-DI registered in the UDI Data Bases. The leading number is the sender's article number, which comes first and is mandatory.

Appendix B: EDI-Mark for invoices

Just as on delivery notes, a 2D symbol in coded form can carry information on invoice forms for automatic capturing the invoice content by scanners.

Invoices are like delivery notes without product properties (lot/series/expiry date), but contain price information.

The P'EDI mark does not contain an electronic invoice but can serve as a data entry aid to support invoice content verification.

The net price per item is calculated from:

Item unit price

multiplied by discount in percent

multiplied by product quantity

Net price per item = unit price × (100 - discount) / 100 × quantity

The gross price is calculated from:

Net price per item

multiplied by the VAT rate of the product in percent

Gross price = net price × VAT / 100

The price for packing and shipping is a purchase order item and managed as a line item identified by a different net price identifier.

The gross invoice total is the sum of the gross prices per item.

Invoice total = gross price item 1 + gross price item 2 + ...
+ gross price packing&shipping

The VAT rate can be specified in the header as a common default and for different rates per product.

The currency is identical for all prices and is specified once in the header in the "Gross total" data field.

Typical data elements for a 2D code on an invoice are shown in Table 12.

Table 12: Data elements for P'EDI INVOICE

Header data	DI	Sequence (Comma does not appear in the code)
Document type	12P	„INVOIC“ (Table 2)
Company ID globally unique according to ISO/IEC15459	18V	18V,IAC,CIN, (DI, Issuing Agency Code, Company ID)
Supplier ID assigned by customer	V	V, Supplier Code
Customer code assigned by the supplier	9V	9V, Customer code
Invoice number	10K	10K, Invoice number
Invoice date	6D..003	6D,YYYYMMDD,003 (003=ANSI X12,3, List 374: Invoice date)
Customer order number	K	K, Data
Suppliers order reference	1K	1K, Data
VAT in percent (default value)	30Q	30Q, value, eg. VAT 19%→ 30Q19
Invoice total gross + currency	12Q..XY	12Q99.99EUR (Euro) 12Q99.99USD /US Dollar, etc. Currency applies to all prices of the invoice
Delivery note with which the goods were delivered	11K	In the case of a collective invoice, the delivery note number is given with the product data per product.
Shipment date	6D..011	6D,YYYYMMDD,011 (011=ANSI X12,3, List 374: Shipped on)
Product data		
Product reference	1P, 54P	Product reference as in table 7
Unit price net product	27Q	27Q,value, e.g. 22,80 →27Q22.80 (currency under „12Qxxx“) „“ dot used as decimal point
Unit price net postage and packing	28Q	28Q,value, e.g. 6.80 → 28Q6.80
Discount in percent	29Q	29Q,value, e.g. 5,5% → 29Q5.5, „“ dot used as decimal point
VAT in percent	30Q	30Q,value, e.g. 7% (VAT supplement applies to the product if different from the default value under 12Q)
Product quantity	Q	Q, value, e.g. 5 pieces → Q5

Appendix C: Combined delivery note with invoice

Delivery note and invoice can be combined in one document. In this case the fields of delivery note (table 1) and of the invoice (Table 12) will be used.

The document type is “DESADV/INVOICE” (Table 2).

The invoice number is mandatory. A delivery note number is optional.

Appendix D: P'EDI QUOTATION

The quotation is like an invoice, with the following differences:

The header segment is "O" and not "S" (Table 5)

Document type: QUOTES (Table 2)

No invoice number but a quotation number with DI "27K" is assigned.

Appendix E: P'EDI ORDER

A purchase order is structured differently from all other document types because it is sent from the customer to the supplier.

Since the part numbers refer to the supplier, the supplier identifier is used as a reference. "18V<CIN>", as in the other document types, becomes "20V<CIN>+SU". This is a supplier reference.

Table 13: Data elements P'EDI ORDER

Header data	DI	Sequence, (Comma does not appear in the code)
Company ID Supplier, globally unique according to ISO/IEC15459	20V<CIN>+SU	20V, IAC, CIN,+SU (SU=EDIFACT Code List 3035 Party Qualifier „Supplier“)
Customer ID assigned by supplier	9V	9V, Customer ID code
Dokument typ2	12P	12P, ORDERS
Order no. of customer	K	K, Data
Ordering date	6D..004	6D,YYYYMMDD,004 (004=ANSI X12,3, List 374: Invoice date)
Quotation no.	27K	27K, Number of related quotation
Shipment address	28L 29L 31L 32L	Number and Street Address City Name. Postal Code Country Code
Purchasing person	H...+BY	H,NAME,+BY (EDIFACT Code List 3035 "Party Qualifier for „Buyer“)
Product data		
Product reference	nP	Product reference as table 7, in the range of the company code of the <CIN> which is indicated at 20V.
Product quantity	Q	Q, value eg. 5pcs→ Q5
Prices	nQ	See table 11
Delivery date	6D.	6D,YYYYMMDD,002 (002=ANSI X12,3, List 374: Delivery Requested On This Date/Time)

Appendix F: Order confirmation

An order confirmation is an offer with price data and delivery date.

Appendix G: Consignment stock filling request

The request to fill a consignment stock is an order, that is not followed by an invoice. As an alternative, the supplier decides to fill up again based on the reported consumption.

Appendix H: Consignment replenishment

The consignment warehouse is supplied from the supplier to the customer. From the data point of view, this type is identical to the normal delivery, except that the document type is set to "CONDESADV".

5 Appendix I: Consignment warehouse return delivery request

The supplier asks the customer to send back goods from the consignment warehouse. For this purpose, this paper EDI type is sent to the customer, whose software executes the process and performs the shipment. So it is a document from the supplier to the customer. In terms of data, it is a delivery bill, with the document type set to "CONBACREQ".

Appendix J: Consignment stock consumption

With the consumption report of consignment goods, goods are ordered for invoicing, whereby batches/serial numbers are already specified. The supplier can start a delivery triggered by the report, or wait for a replenishment request.

Appendix K: Credit note

A credit note is like an invoice with part number and possibly product data such as batches/serial numbers and referencing to an invoice.

Appendix L: Return delivery

The return delivery is a delivery bill in which the included CIN and order numbers originate from the recipient. The original invoice reference is relevant to which this credit note applies.

Appendix M: SET Code

A set product is logistically a product with product data article number, lot, serial number, expiry date etc., which contains several sub-products.

The sub-products, are provided with their own product data article number like lot, series, expiry date.

Up to now, such set products are only marked with the product data of the set product without content information. For logistical operations such as breaking open the set or for warranty claims, it may be helpful to make the contained items transparent from the outside by scanning. A SET Code is like P'EDI, the whole content can be captured by scanning the P'EDI SET Code symbol.

M1: Data elements of a SET Code

The set code for this consists of the following levels (Table 5):

- Product level: "I" (Item) contains the product data of the set
- Component level: "F" (Component), contains the product data of the subproducts
- Serial number level: "X" (SN, date, etc.), contains the product properties of the sub-products.

The product data from table 14 can be included for the set product in the I segment and in several subproducts in F segments as well.

Table 14: Data elements SET Code

Header data	DI	Sequence (Comma does not appear in the code)
Company globally unique ISO/IEC15459	18V	18V, Issuing Agency Code, Company ID
Product data		
UDI-DI of the product	54P	54P, UDI-DI
Manufacturer's product without company code	1P	1P, Product ref. (Manufacturer ID is behind "18V") (no mandatory field)
Expiry date	14D	14D, JJJJ,MM,TT, e.g. 14D20301012
Lot no. of manufacturer	1T	1T, Lot
Serial no.	S	S, Serial no.
Quantity	Q	Q, pcs.
Internet link (URL)	33L	Uniform Resource Locator (URL). contains all characters of a URL, e.g. http://..., character set according to RFC 1738

M2: Structure and syntax of a SET code

As a structure for coding a SET code into 2D codes, the following options can be used, which are comparable with Table 12:

Option A) is the application of

„DIN 16598 syntax for keyboard and internet compatible encoding of data elements using ASC DI's“.

This option has the advantage that the data can also be transmitted via a keyboard interface, since no special characters are included.

The "dot (.)" serves as system identifier according and the character "circumflex (^)" serves as separator between the concatenated data fields. Both characters are keyboard compatible.

Option B) is to use the ISO/IEC 15434 syntax, as in PaperEDI for large data volumes of a 2D code or for multiple formats in one code (see Chapter 4).

Table 15: Syntax A) DIN 16598 and B) ISO/IEC 15434 for SET codes in comparison

	Start	ASC DI, Data	Separator	ASC DI, Data	Separator	etc.	Stop
A) DIN 16598	•	18VQCELM I	^	1P123XYZ	^	-----	
B) ISO/IEC 15434	[]> ^R _s 06 ^G _s	18VQCELM I	^G _s	1P123XYZ	^G _s	-----	^R _s ^G _s

Note: Option A) is recommended for small to medium data volumes, option B) where multiple data formats occur in one symbol.

Appendix N: Emblem P'EDI and SET

Emblems attached to a 2-dimensional symbol indicate that it is a code containing a standardized structure that can be interpreted by standard means and provides information about the contents. The emblems are added in horizontal or vertical arrangement to the relevant symbol at the distance of the "quiet zone, but at least 2mm.

The graphics are available for download in common formats and sizes at www.e-d-c.info .

N1: Emblem P'EDI

The P'EDI emblem indicates that it is standardized data content for a delivery corresponding to an EDI message a delivery advice consisting of header data and content information. The emblem is added to 2D symbols that carry contents and structures according to the specification "PaperEDI".



Figure 14: P'EDI Emblem in horizontal and vertical arrangement

N2: Emblem „SET“

The "SET" emblem indicates that it is standardized data content for a product or object set. This can be a grouping of products located in a container or components located in a device. The higher-level label, on which the data is coded as a set in a 2D symbol, called a set label. The contents and structures also correspond to the "PaperEDI" specification.



Figure 15: SET Emblem in horizontal and vertical arrangement

Appendix O: Internet link to general, process and object related information

A direct link to an Internet page can be integrated in an EDI mark as in a SET code by help of the data identifier "33L Uniform Resource Locator (URL)". This enables the application to locate the link from the data string and to establish the Internet connection. This allows information to specific applications, e.g. general product information but also very specific process or object related information. In this way, for example, access to specific maintenance information can be provided. Figure 16 below illustrates the integration of an Internet Link using the example of a SET code.



```
]><RS>06<GS>25PLHEGST220180LR<GS>1T02082098-74507B14<GS>S67253952<GS>33LHTTP://WWW.EDIFICE.ORG<RS><EOT>
```

Figure 16: URL integrated in SET code using ISO/IEC 15434 syntax as link to a specific Internet address.

Appendix P: P'EDI via data line

As well as via 2D symbol, messages can be transmitted via data line, so P'EDI messages as well.

Multiple P'EDI codes can be transmitted as "one" data string. For this purpose, all segments will be connected completely. The connection is established via the data identifier "4F" (see table 1), which is also responsible for linking the content of multiple symbols belonging together.

Example of a data string of a P'EDI or SET code transmitted by data line, here the data of two symbols:

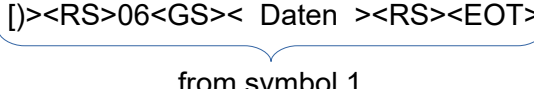
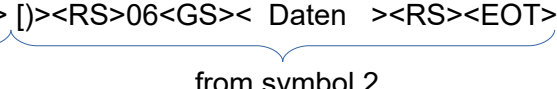
<pre>[]><RS>06<GS><< Daten ><RS><EOT> []><RS>06<GS><< Daten ><RS><EOT></pre> <div style="display: flex; justify-content: space-around; margin-top: 10px;"> <div style="text-align: center;">  <p>from symbol 1</p> </div> <div style="text-align: center;">  <p>from symbol 2</p> </div> </div>
--

If the file has a filename, the following pattern is suggested:
<document type><document number>.pdi

Example: Delivery note number 12: "DESADV12.pdi".

Appendix Q: Standards, references and sources

Standards relevant to „PaperEDI“ and „SET-Code“

ISO/IEC 15434 Syntax for High Capacity Media
 ISO/IEC 15418 GS1 Application Identifiers and ASC Data Identifiers
 ISO/IEC 15459 Unique Identifiers
 ISO/IEC 16022 Data Matrix
 ISO/IEC 18004 QR Code
 ISO 22742 Packaging
 ANS MH 10.8 ASC Data Identifiers
 ANS HIBC 2 Health Industry Bar Code
 IFA-Coding-System, Specification PPN-Code
 GS1 Global Specification
 DIN 16598 Syntax for keyboard and internet compatible encoding of data elements into machine-readable symbols using data identifiers.

Sources for "PaperEDI" realization

ANSI, DIN and ISO standards: www.DIN.de
 Support: EDCi TC, www.e-d-c.info
 Tools: Elmi-PrintLink „PaperEDI“, ScanLink Integration, www.elmicron.de
 UN-EDIFACT: Description of the data record structure for the electronic exchange of order data, www.BVD.de